

EVOLUTION COLD FRAME



Cedar Greenhouses

Instruction Manual



Made in the United Kingdom

Please read all instructions before proceeding



Cold Frame Instructions

Contents:	Page
Introduction	2
Front Assembly	3-5
Rear Assembly	6-9
Frame Assembly	10-12
Base Assembly	13-14
Glazing	15-18
Lid Assembly	19-24
Optional Cedar Panels	25-29
Packing List	30-31

Thank you for purchasing your new Alton cold frame. We recommend you familiarise yourself with the instructions and read all safety information before you commence assembly. Helpline 0800 085 0005

Safety Warning

- Glass, aluminium and timber can potentially cause injury. Please ensure you wear protective goggles, gloves, headgear and suitable footwear when assembling and glazing the building.
- Please remember that glass is fragile and should be handled with extreme care. Always clear up and dispose of any breakages immediately.
- Do not assemble the cold frame in high winds.
- To minimise the risk of wind damage, try to select as sheltered a site as possible, e.g. beside a hedgerow or garden fence.

Additional Considerations

- You will find it easier to use a large table or workbench to construct the cold frame so that everything is at an accessible height. A garage floor or flat lawn area is a good alternative.
- If you have arranged for someone to build your cold frame for you, please check that all components are included. Most parts are numbered and can be identified by a stamp or removable label. Alternatively, the components can be identified by lengths detailed on the packing list in the back of this booklet.

Front Assembly

To start building your cold frame you need the two components below. First use the drill bit provided to drill a pilot hole through the bottom of the mortise. It is important to always drill pilot holes before inserting a screw to prevent the parts from splitting. This should be as close to the centre of the slot as possible, diagram 1.

Slot the middle glazing bar (EV0821) in the mortise hole of the front cill and fix with a 50mm screw.

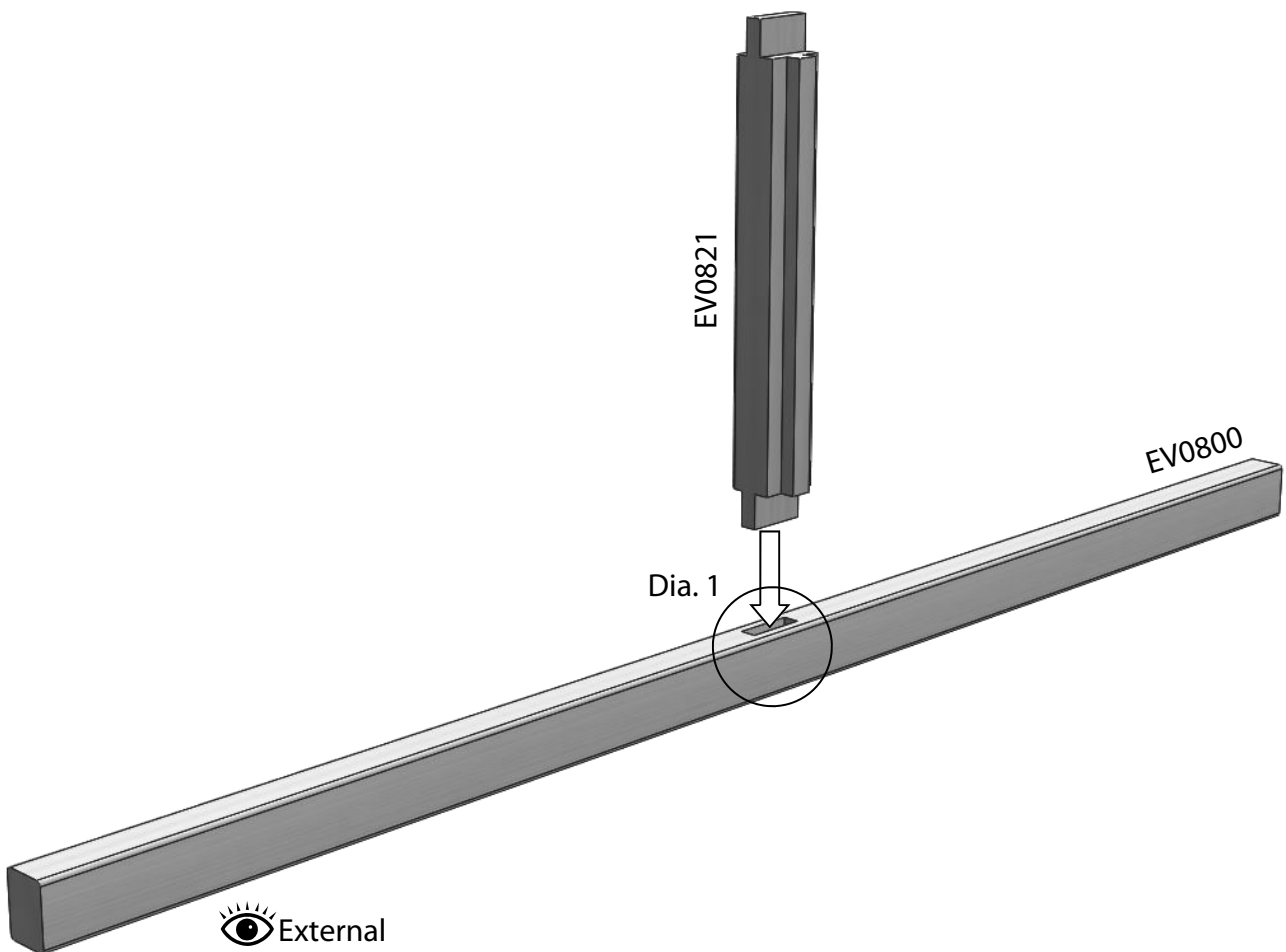
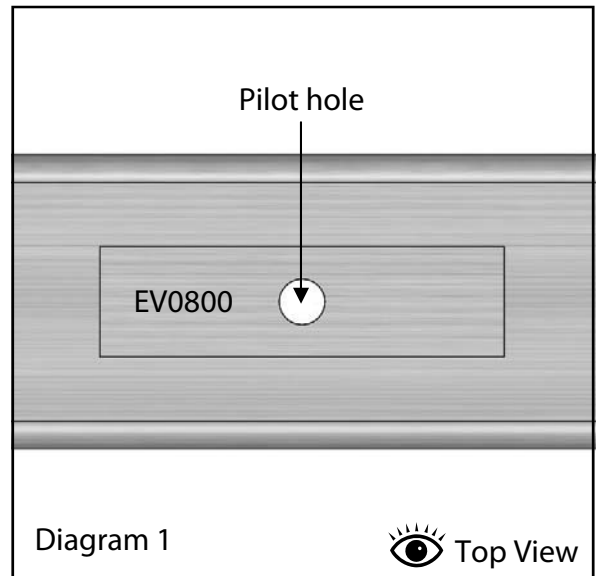

Front Assembly

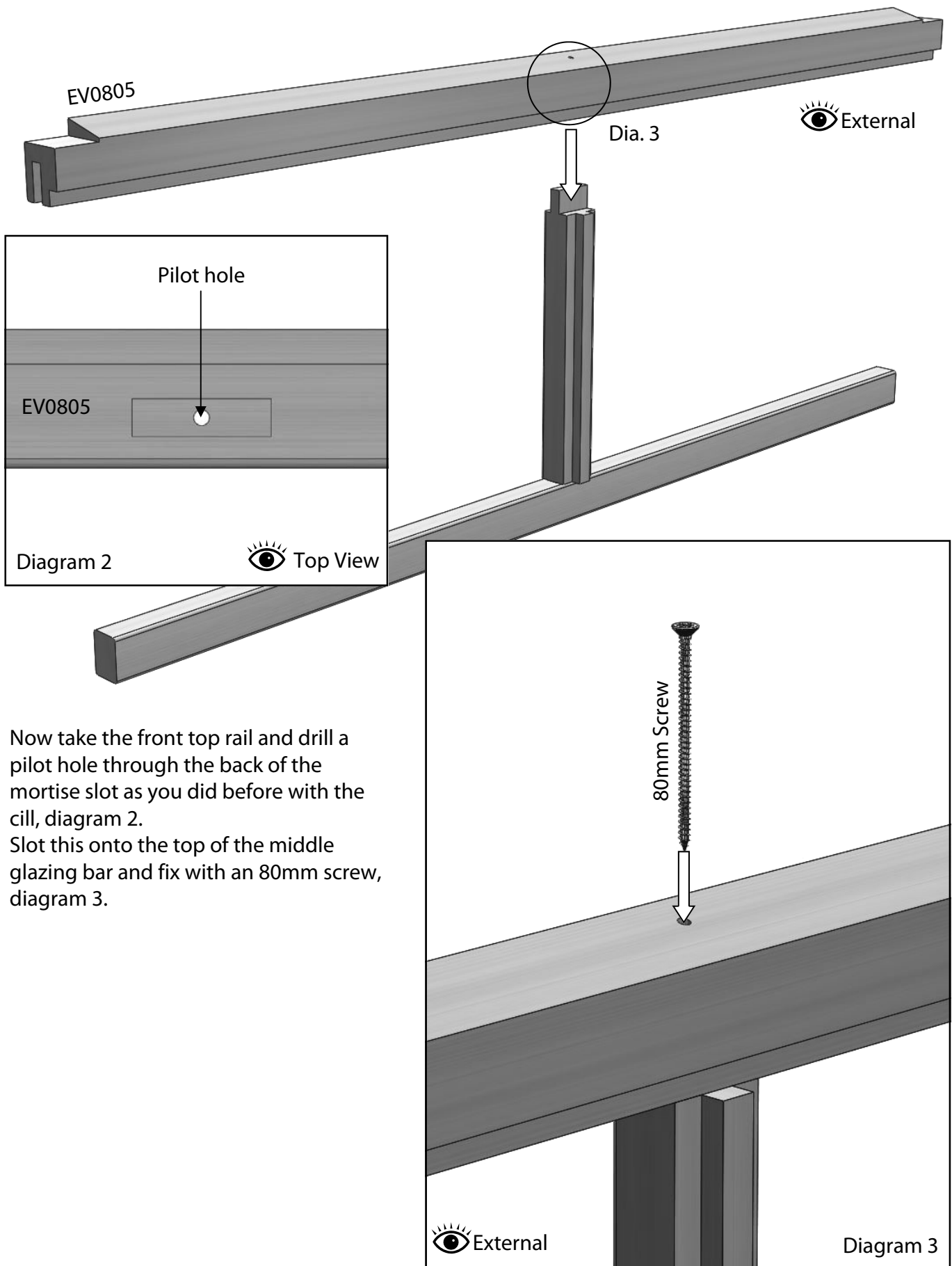

Now take the front top rail and drill a pilot hole through the back of the mortise slot as you did before with the cill, diagram 2. Slot this onto the top of the middle glazing bar and fix with an 80mm screw, diagram 3.

Front Assembly

You now need to fit the front corner bars, before doing this drill pilot holes in the bottom of the bar shown in diagram 4. This is showing the left hand bar, you will need to measure from the opposite faces for the right hand bar. Make sure the hole in the narrow face lines up with the mortise.

Once drilled slot the bars onto the assembly. Line the bottom front face up with the front face of the front cill and fix, diagram 5.

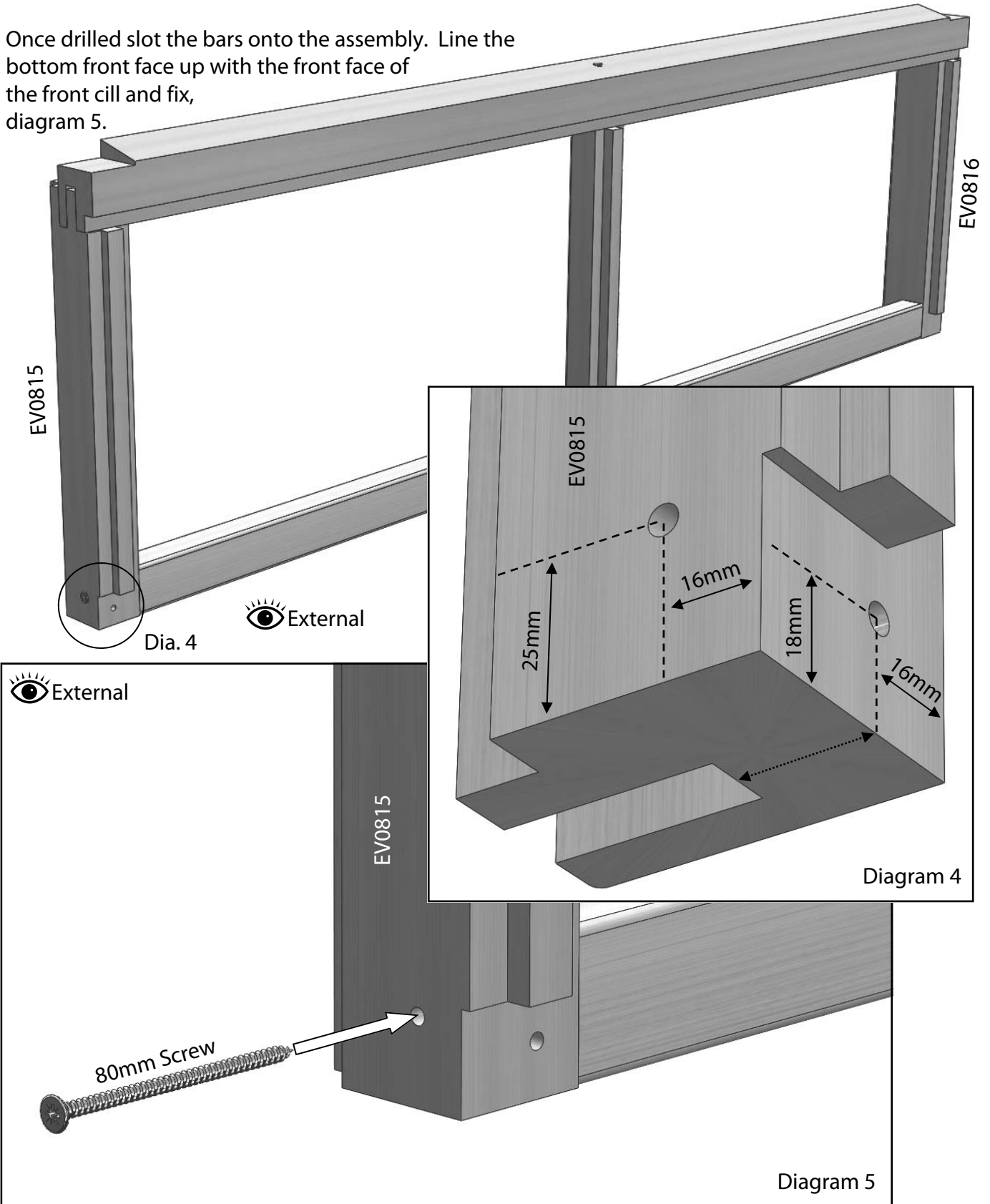

Rear Assembly

As before drill a pilot hole through the mortise then slot the rear middle bar into the rear cill. Fix with a 50mm screw.

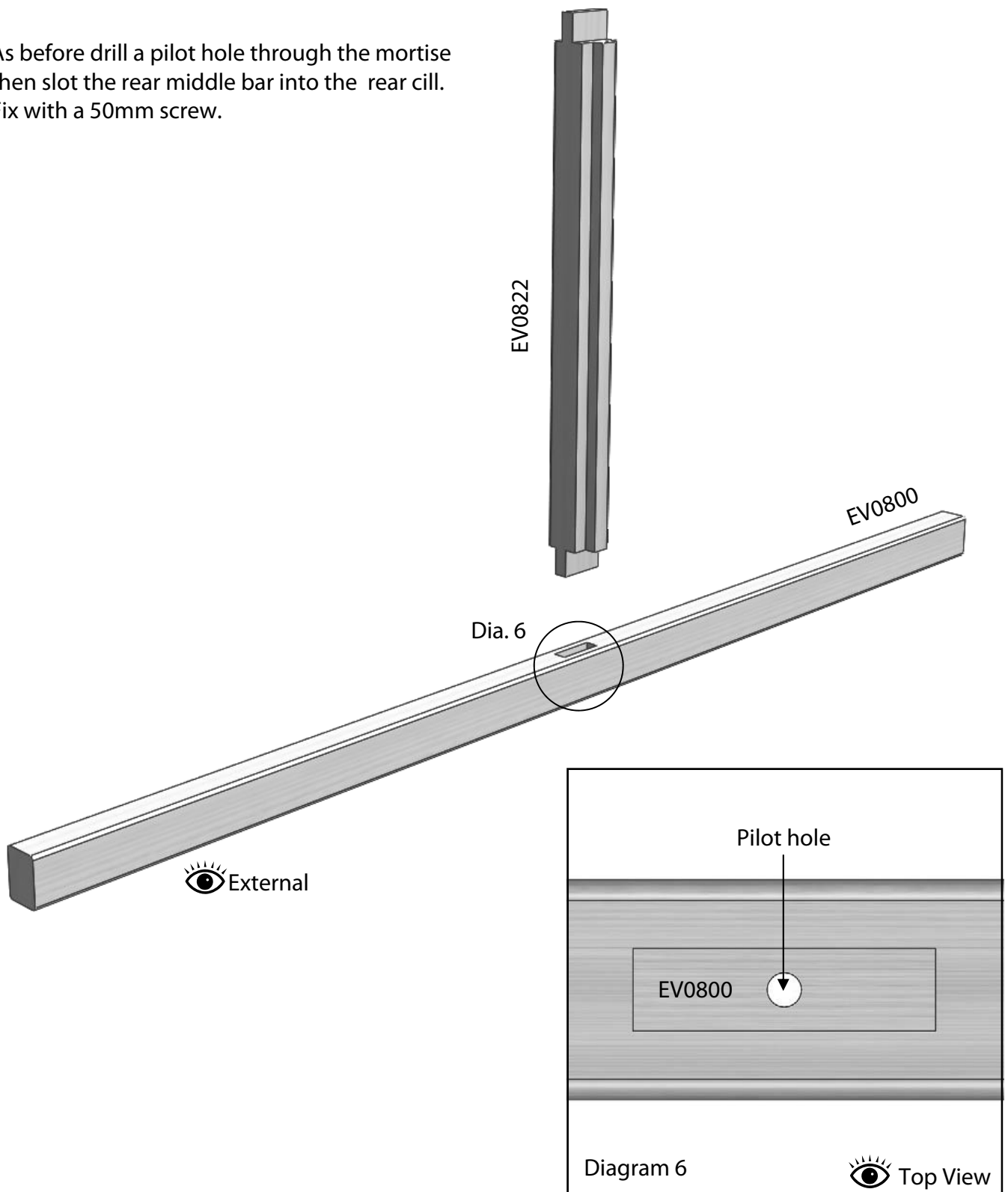

Rear Assembly

Now drill pilot holes in the rear top rail, diagram 7. This time you need to drill 3 holes, one in each mortise, as shown below.

You can then slot the top rail onto the top of the middle bar. Make sure you get this the correct way round, the rebates on the middle bar should line up with the rebate in the back of the top rail.

Then fix with an 80mm screw, diagram 8.

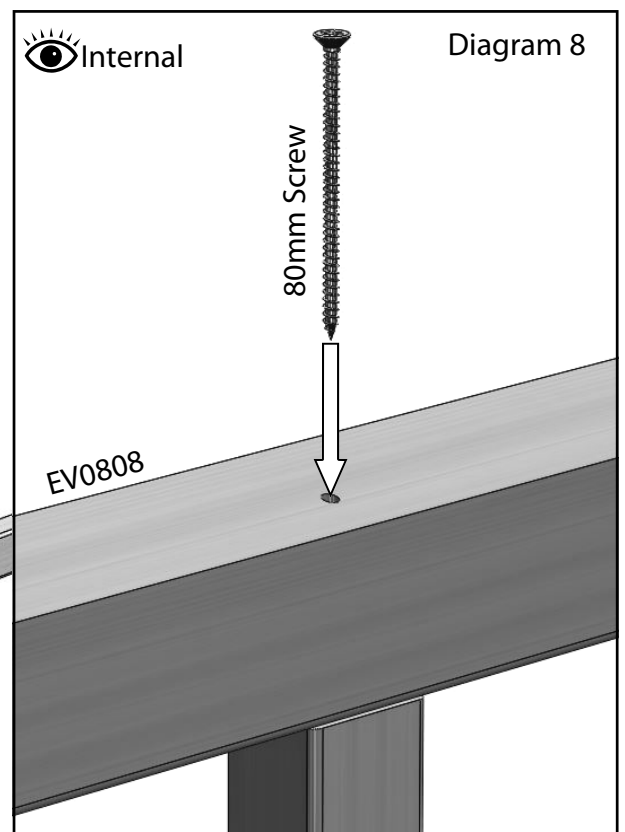
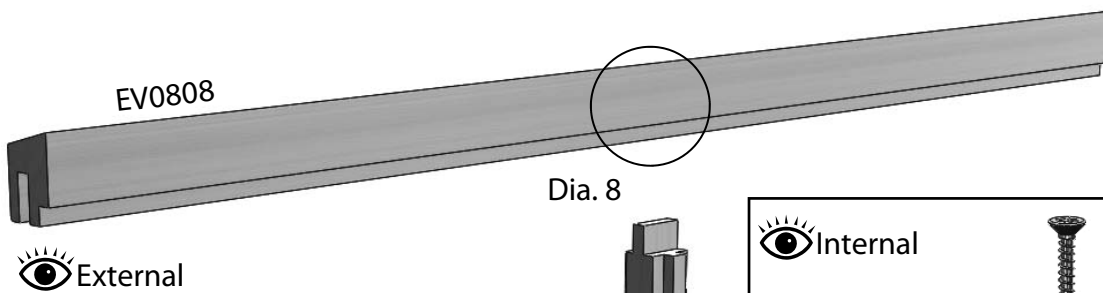
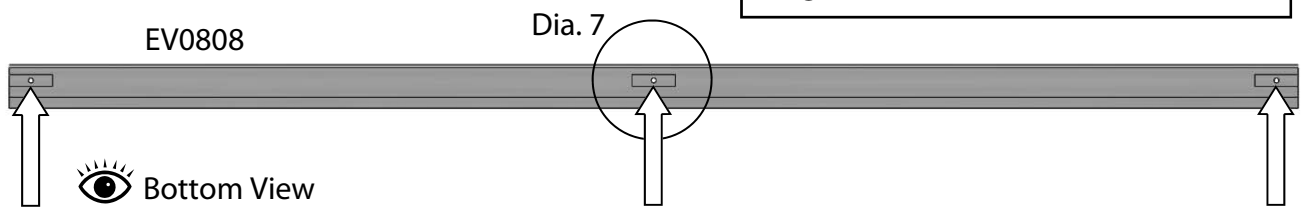
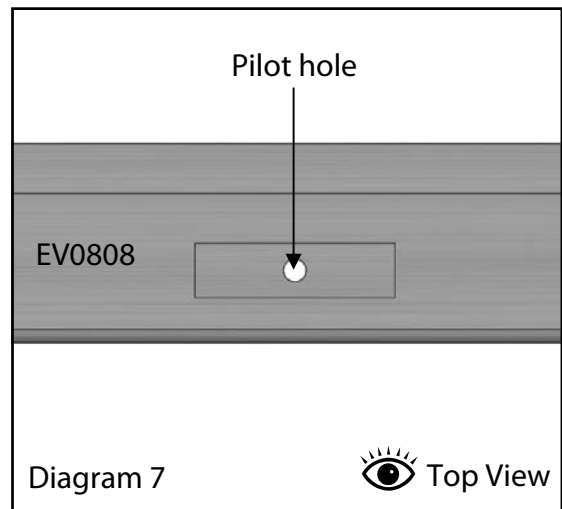

Rear Assembly

Again before you fit the rear corner bars drill pilot holes as shown in diagram 9. Slot these onto the rear top rail and fix to the rear cill with an 80mm screw, diagram 10.

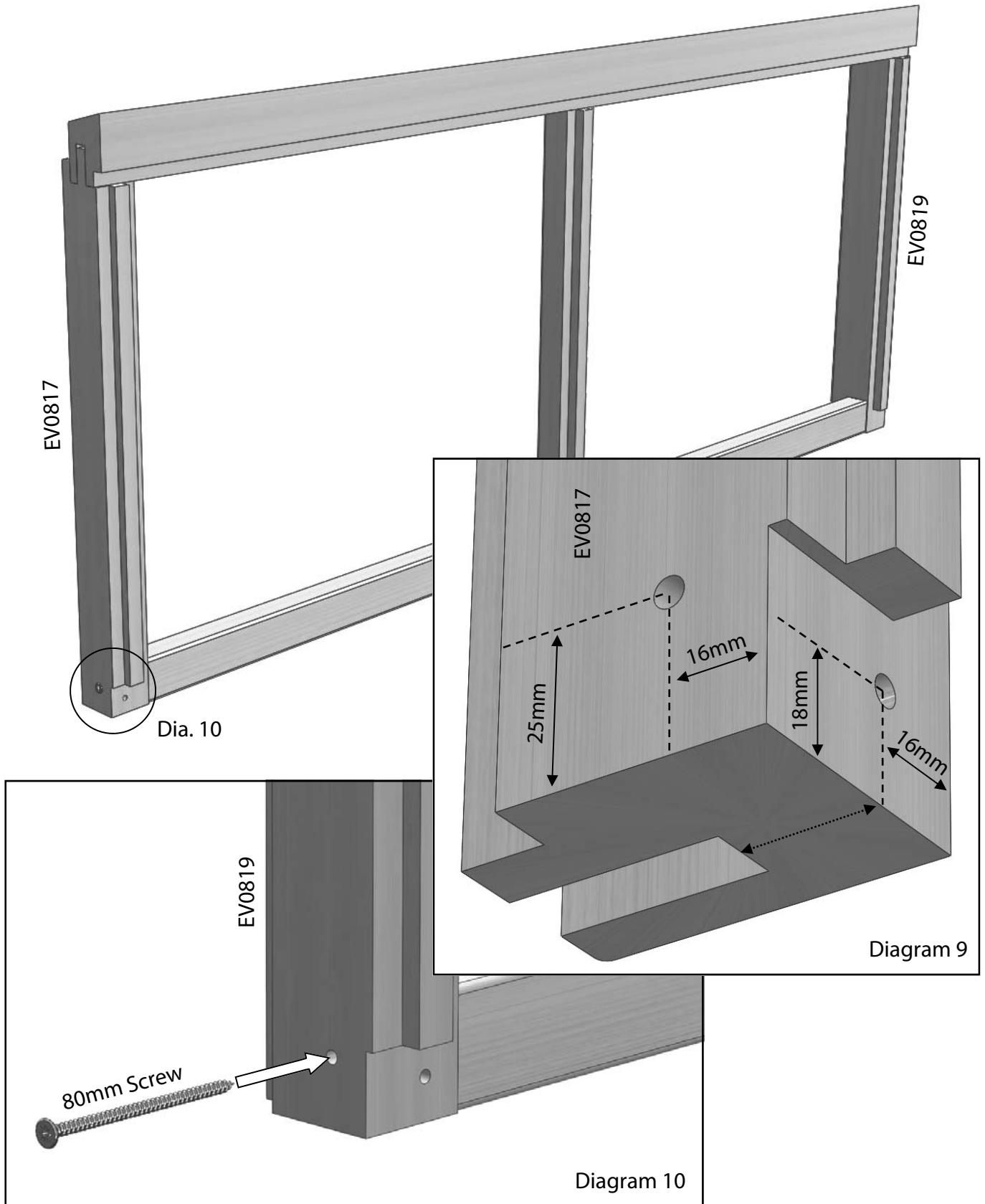

Rear Assembly

Now fix the top of the rear corners to the top rail with 80mm screws as shown below.

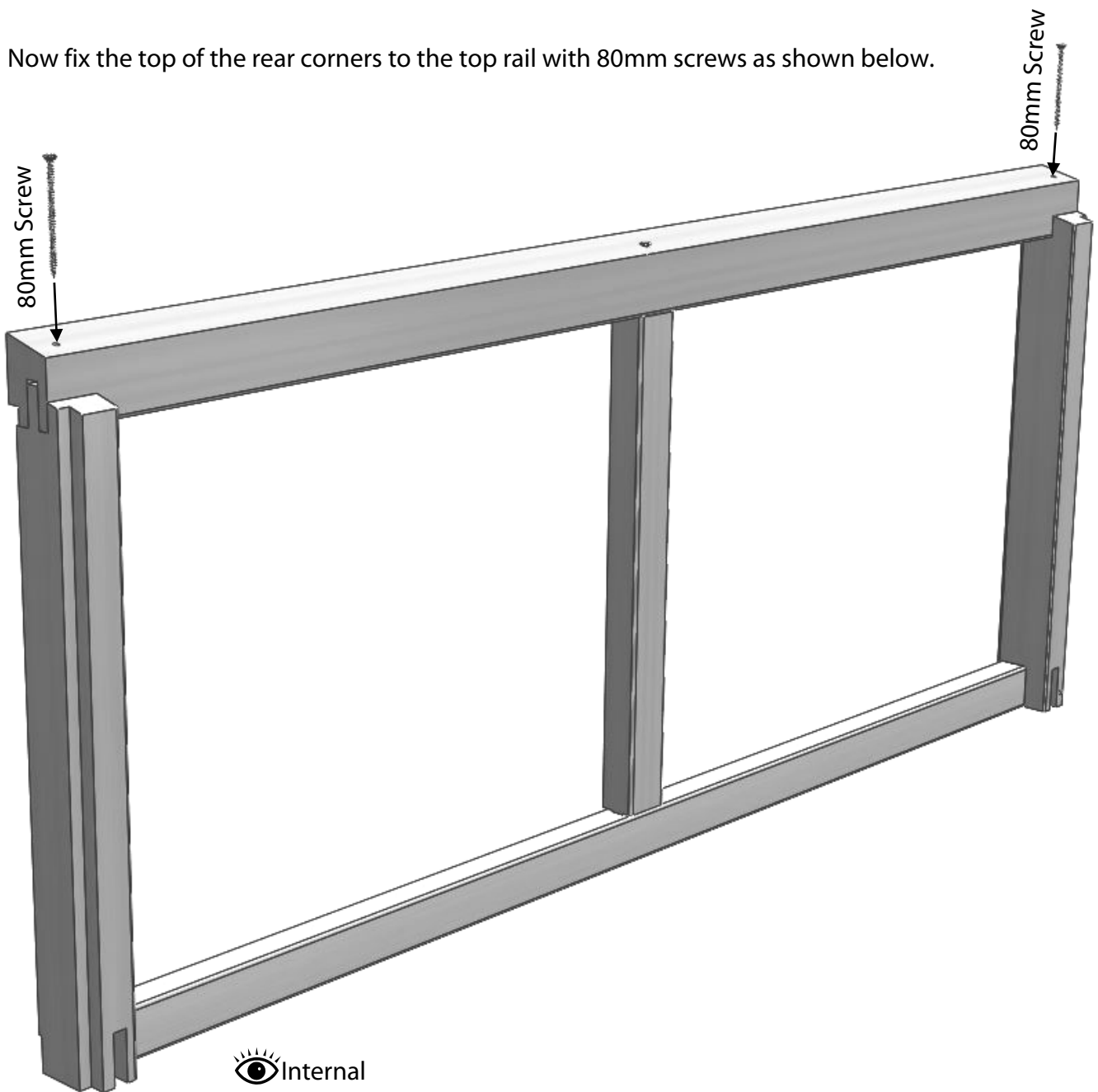

Frame Assembly

Now you have the front and rear frame assembled you can fit the side cills. First of all take the front frame and one side cill, slot this into the mortise hole and fix with an 80mm screw (diagram 11). Repeat this at the other end of the front frame.

Now slot the rear frame onto both side cills, again fix with 80mm screws.

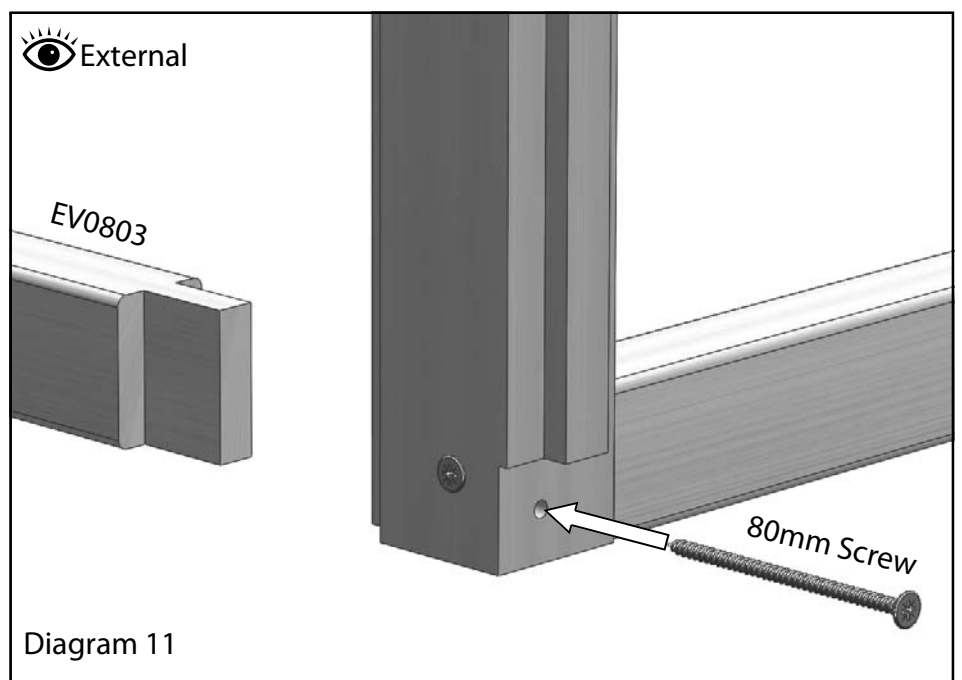
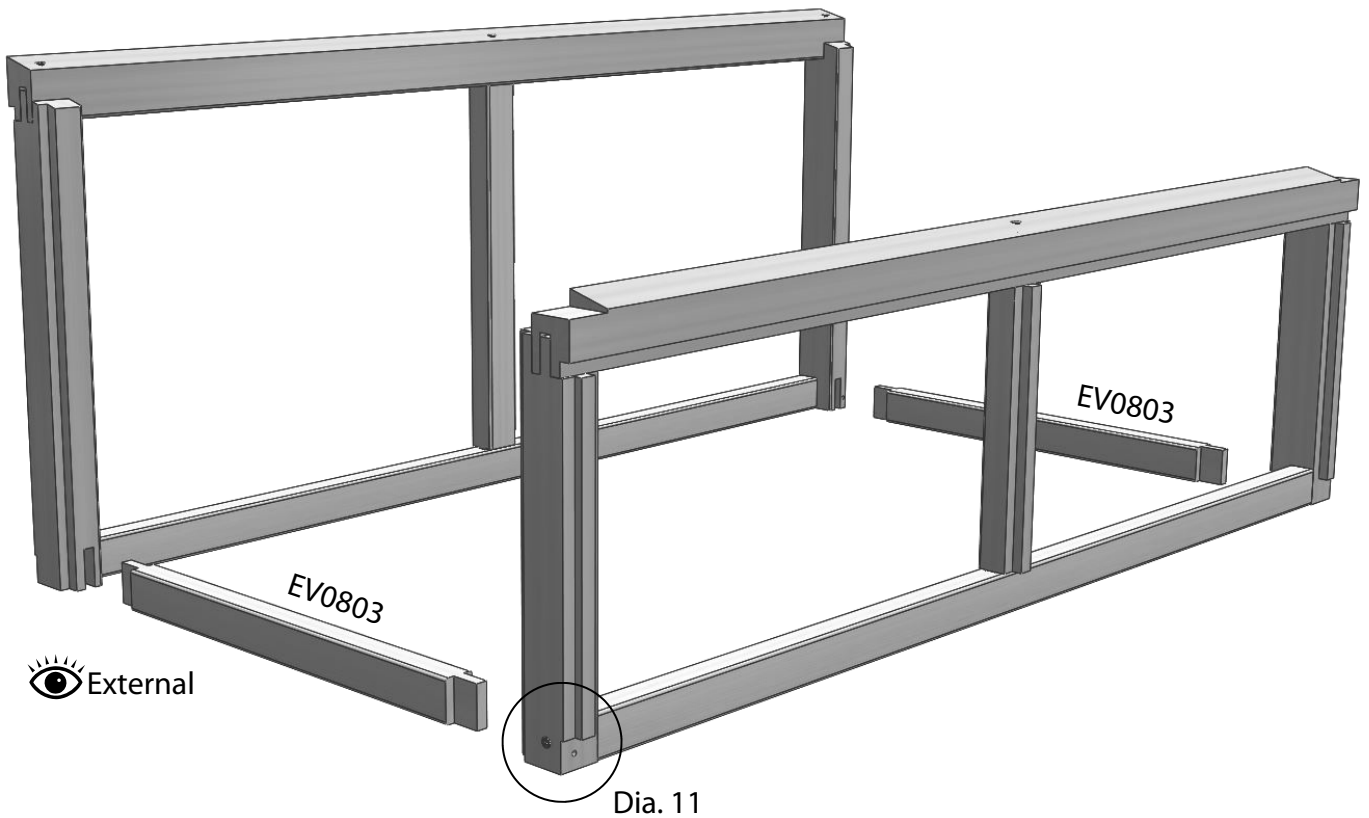

Frame Assembly

Next you need to fit the top side rails. You should slot this into place and drill pilot holes in situ. Diagram 12 and 13 show the position of the hole along the bar, make sure you drill down vertically so you screw into the correct section of timber below. The holes should be in the centre of the top side rail.

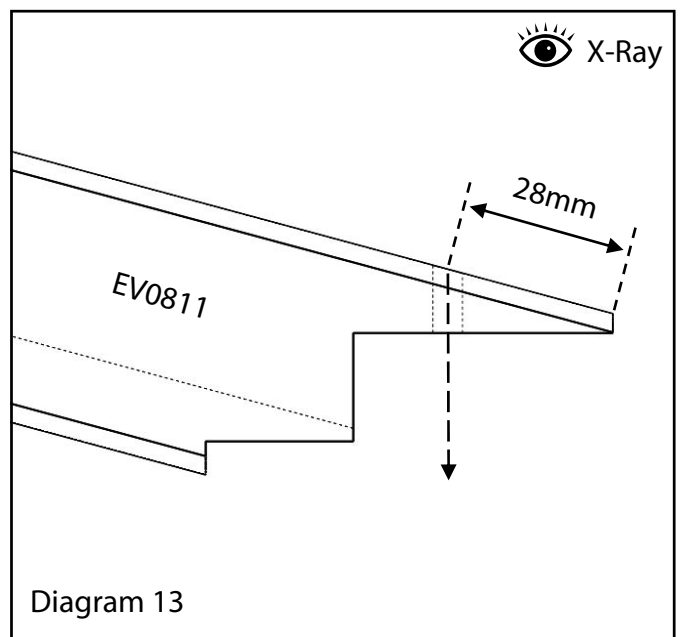
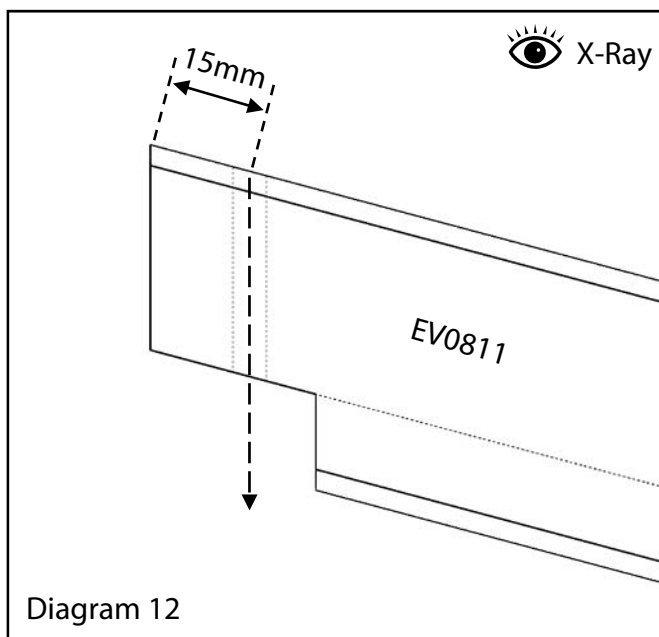
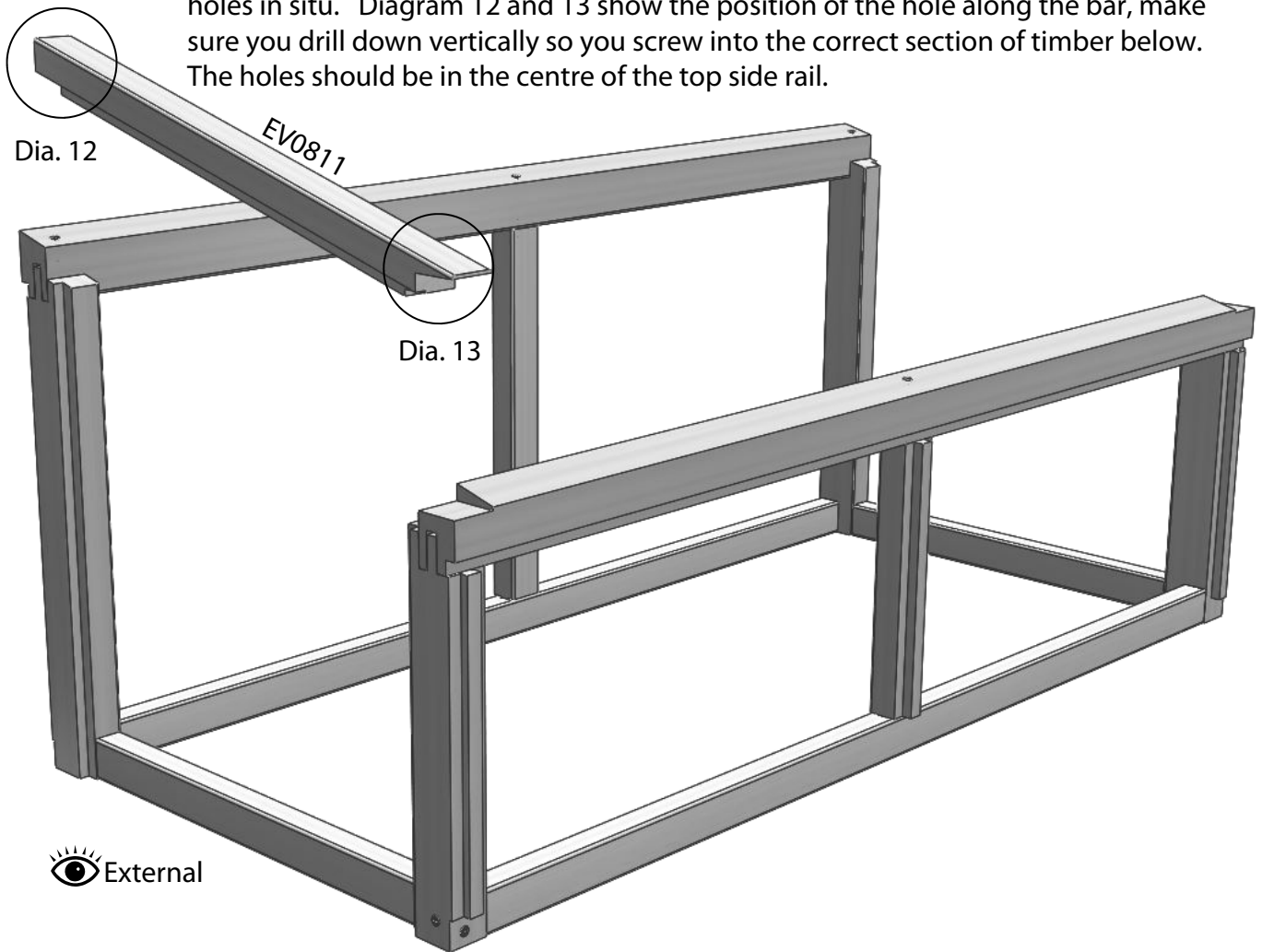

Frame Assembly

Now the pilot holes are drilled you can fix the top side rail with a 50mm screw at the top (diagram 14) and an 80mm screw at the bottom (diagram 15). Repeat this on the right hand rail.

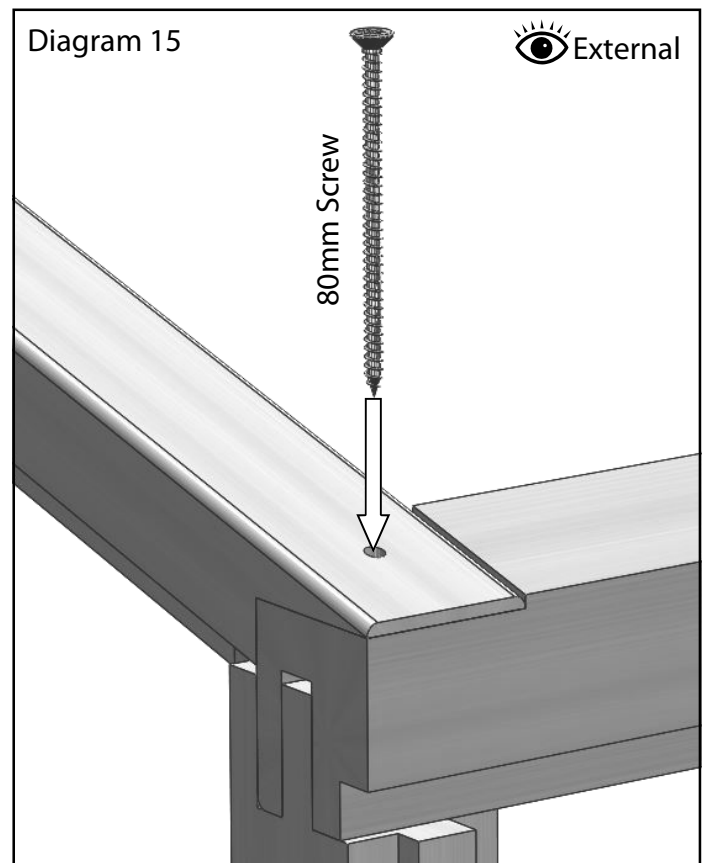
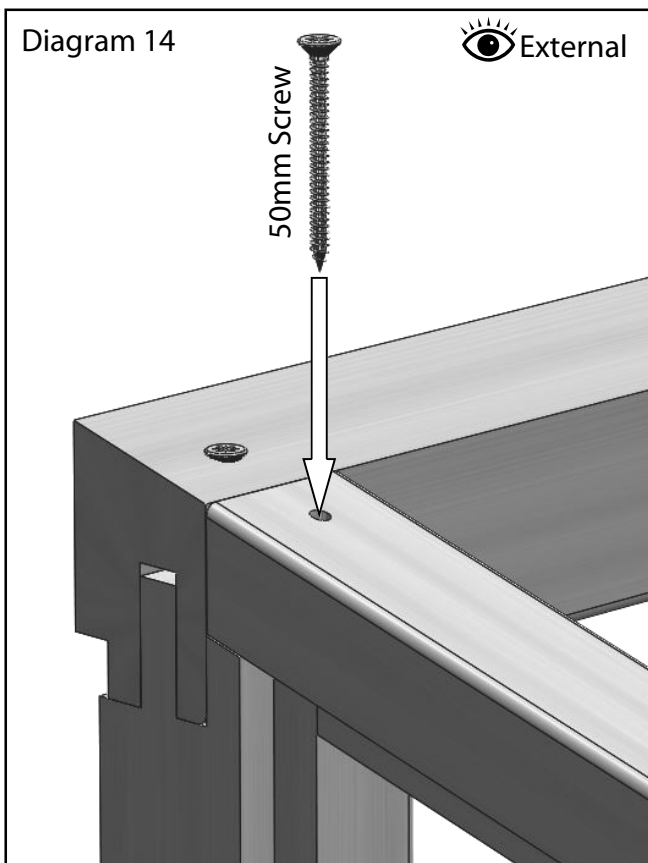
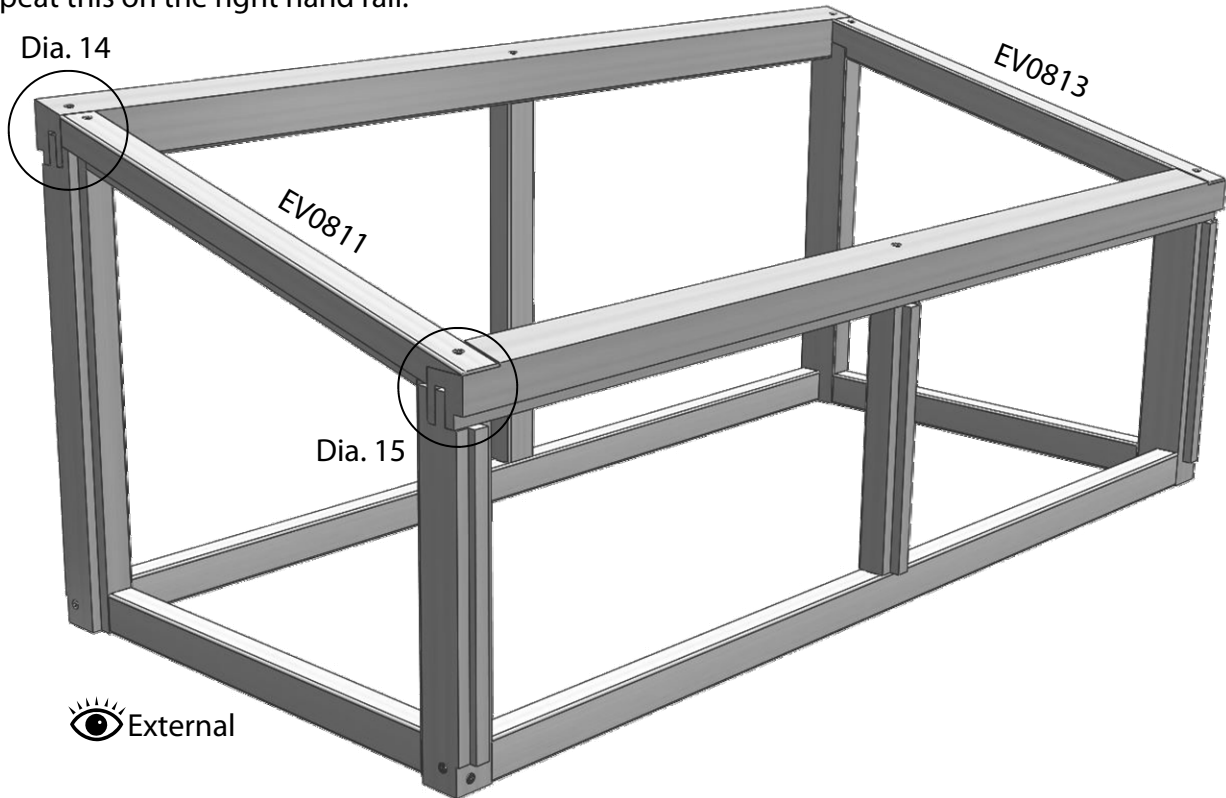

Base Assembly

Now the frame is complete you can move that to one side and assemble the base sections. Lay them out as shown below. Use the 4 corner brackets (EV0311M) with the M6 nuts and bolts supplied to join the sections together. For now just fit the nuts finger tight.

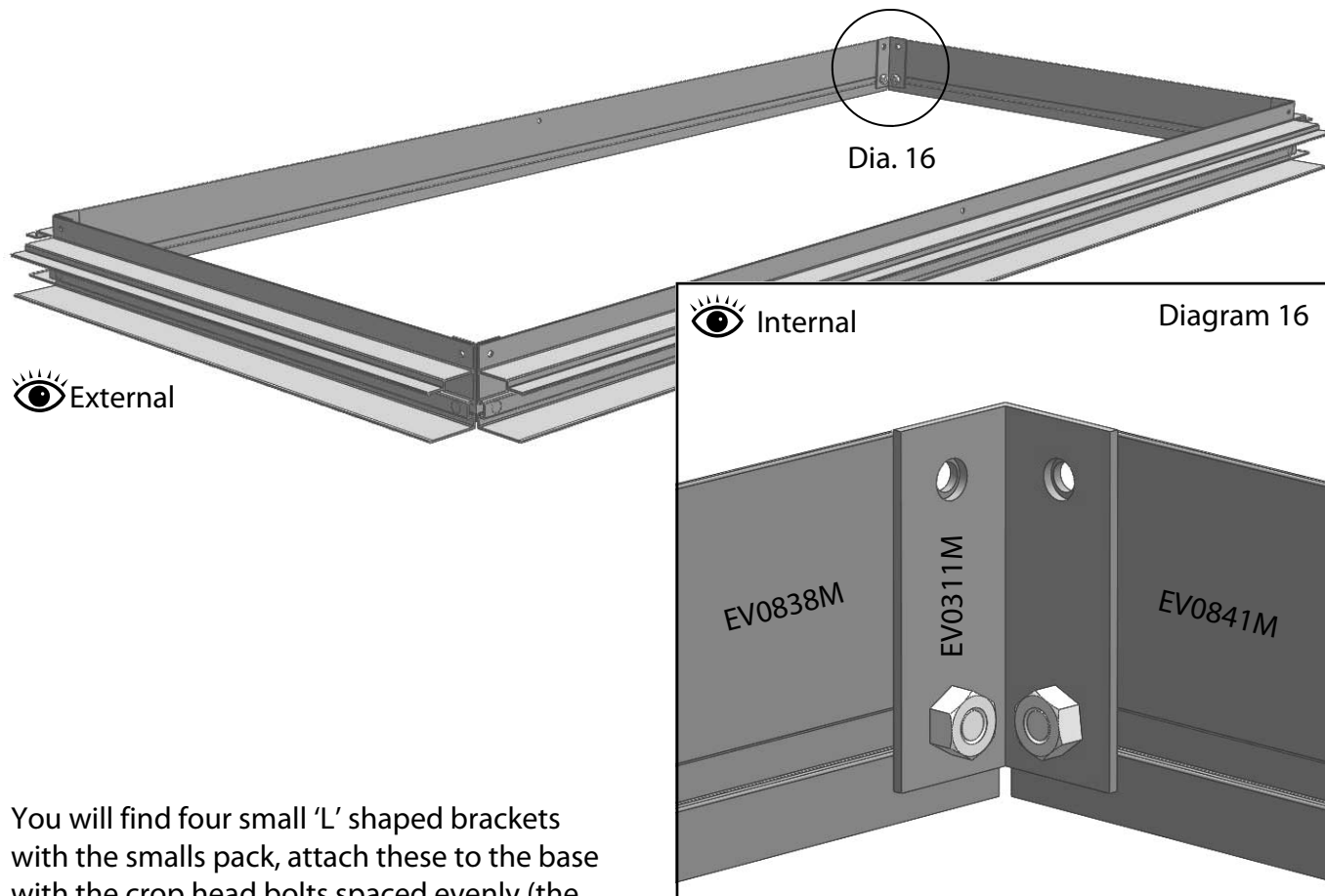

You will find four small 'L' shaped brackets with the smalls pack, attach these to the base with the crop head bolts spaced evenly (the block arrows below show where these could be installed).

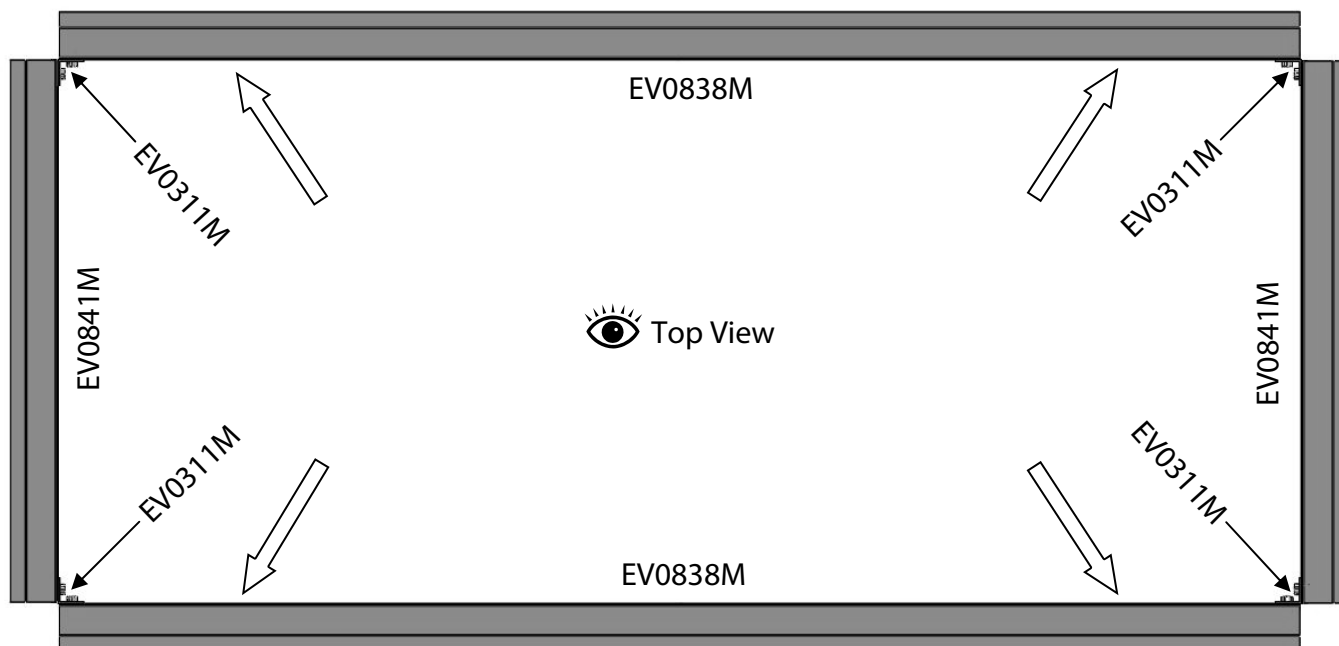

Base Assembly

Now lower the frame onto the base, you may find you need to adjust some of the corner brackets to allow the frame to slot onto the base. Once fitting well tighten the nuts.

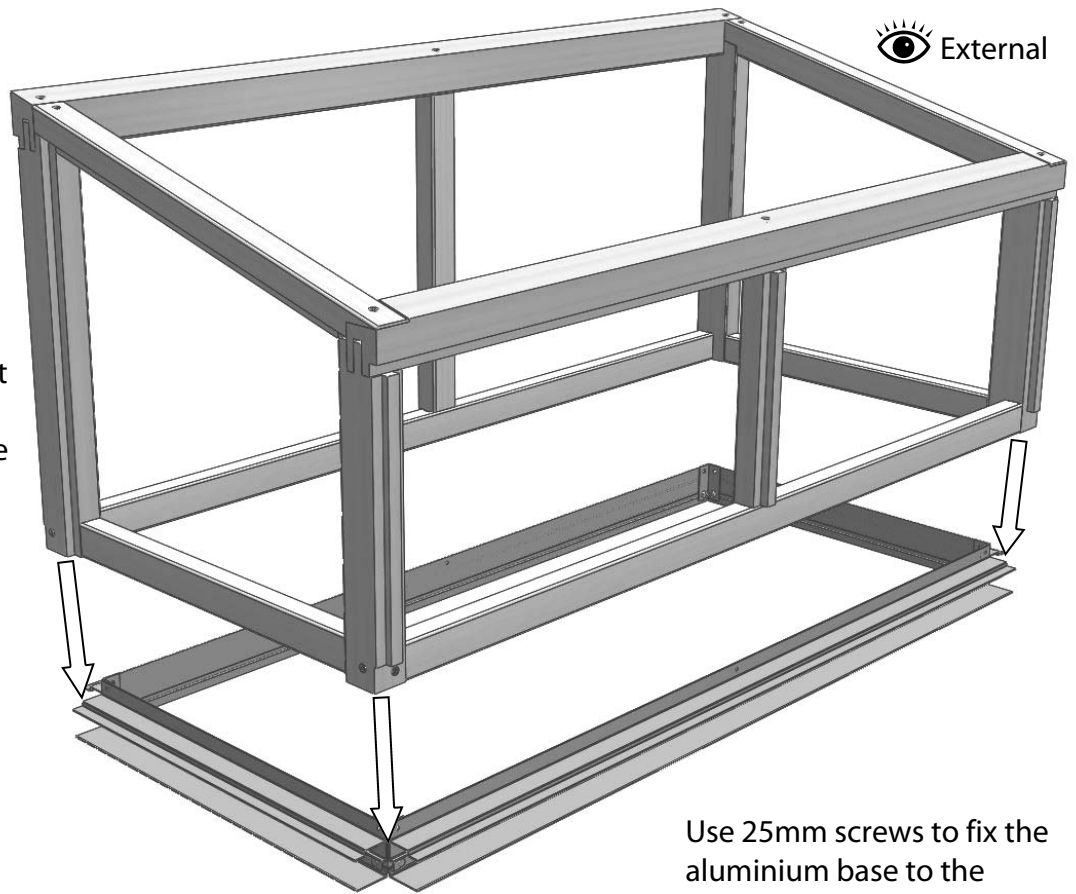

Use 25mm screws to fix the aluminium base to the frame. These should go in all of the pre-drilled holes including the top holes of the corner brackets.

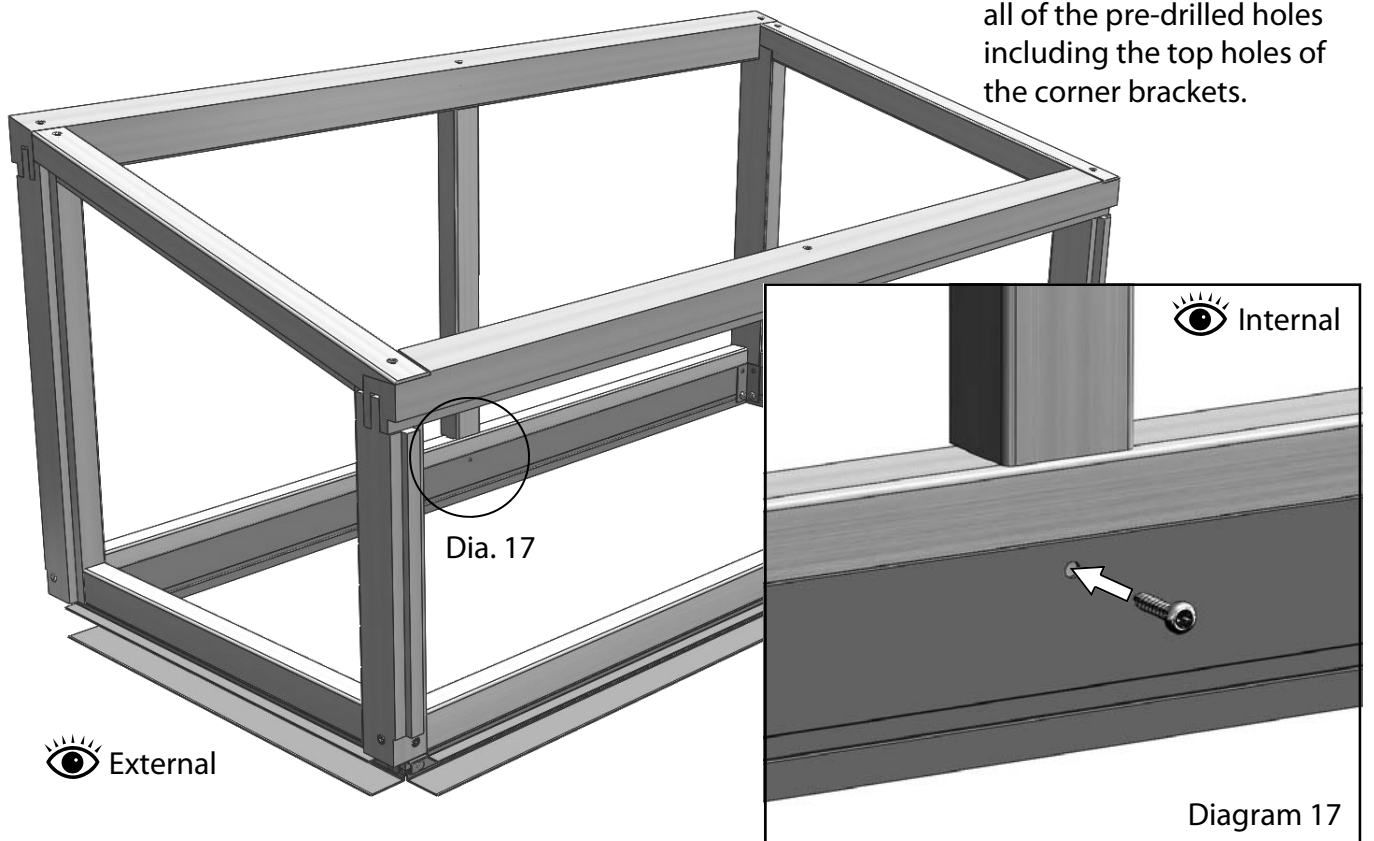

Glazing (If you are using the cedar panelling kit please go to page 25)

If you have aluminium capping you do need to glaze the sides in a slightly different order than shown below, if you are glazing with cedar capping carry on as normal.

Aluminium capping: Insert glazing rubber into all of the capping pieces where there is a channel. Next insert the side pane and fix in place with the capping sections that only have one channel. Fix with 25mm screws. You can then fix the side cloaking board (EV0826) as described below.
(Aluminium part numbers shown in brackets)

Description: Alton Evolution Cold Frame 2ft x 4ft Glass List		
Product Code	Description	Quantity
610x354	TG 610 X 354	2
610x508	TG 610 X 508	2
EV509x514x378	TG 509 x 514 x 378 Trapezium	2
610x610	TG 610x610	2

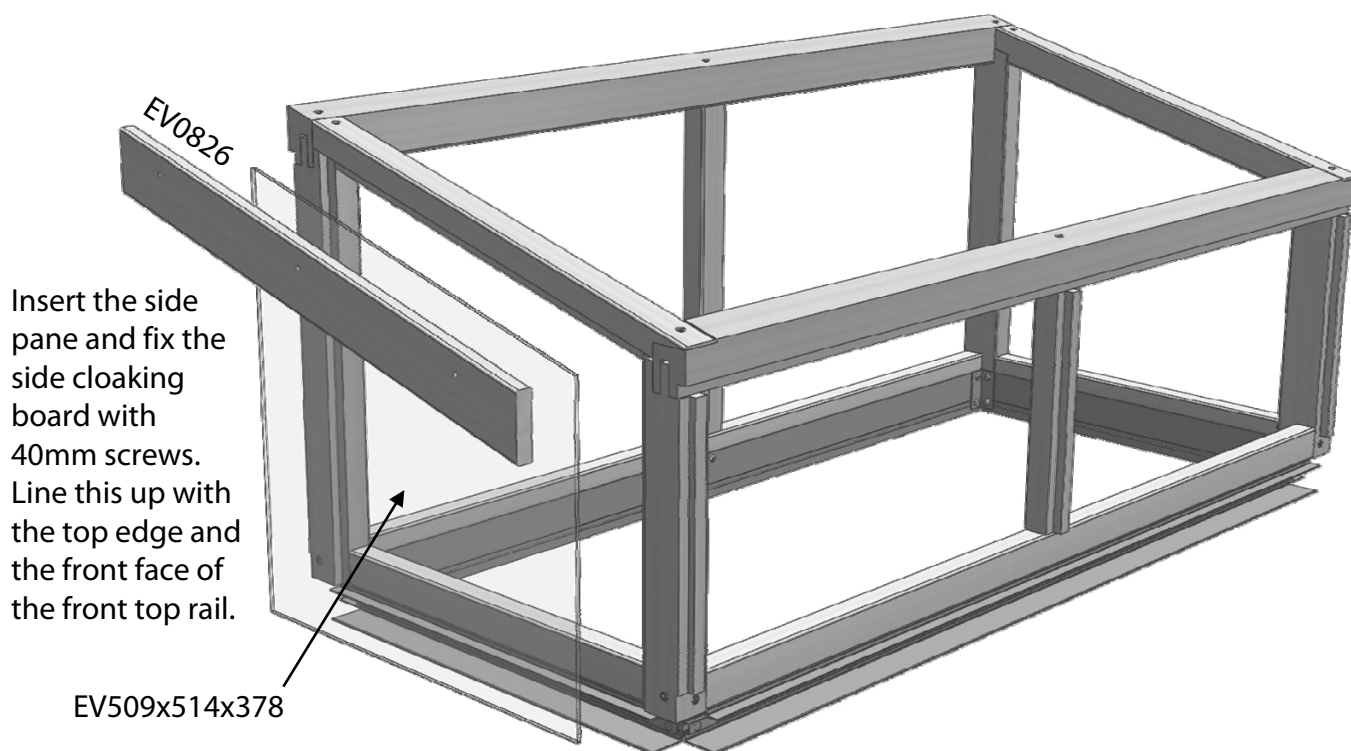

Glazing

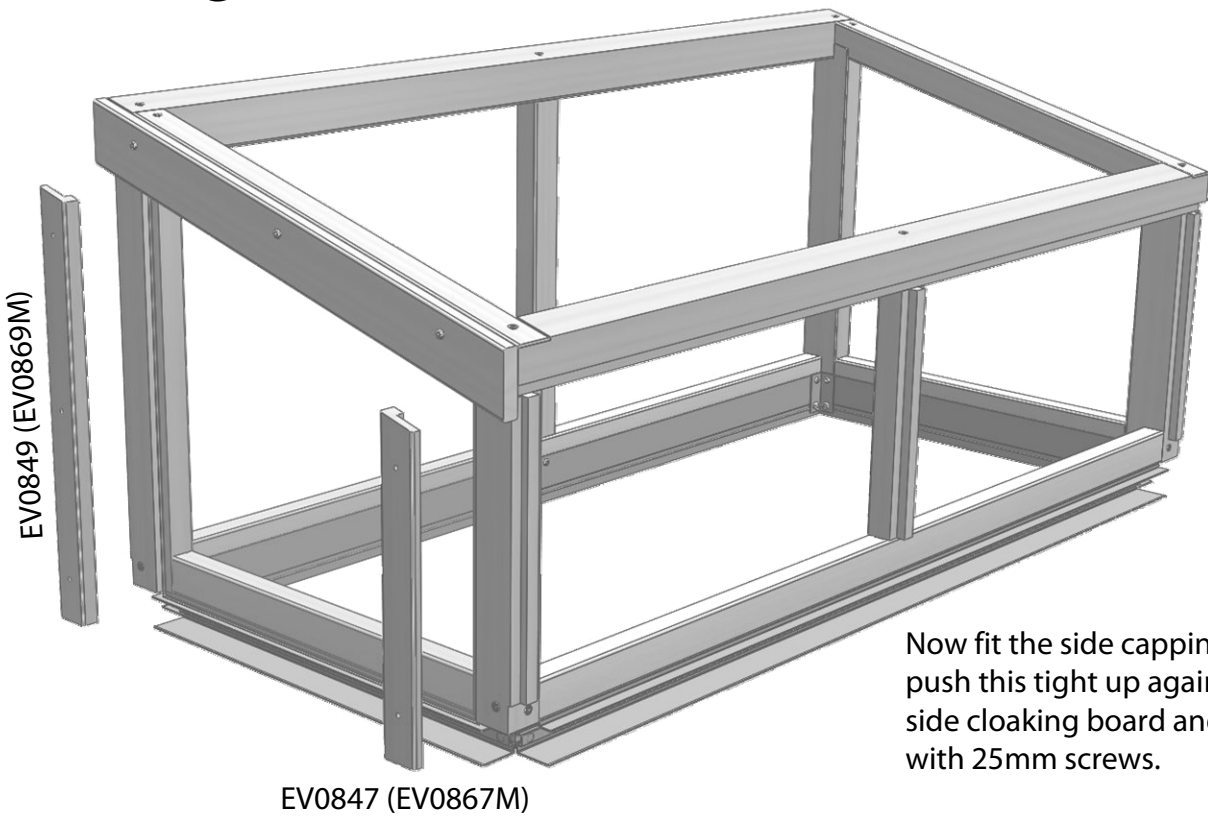

Continue working round the cold frame by glazing the front. Insert the front pane and fix with the first piece of capping, the capping should be flush with the top of the glazing bar it is being fixed to. Fix this with 25mm screws.

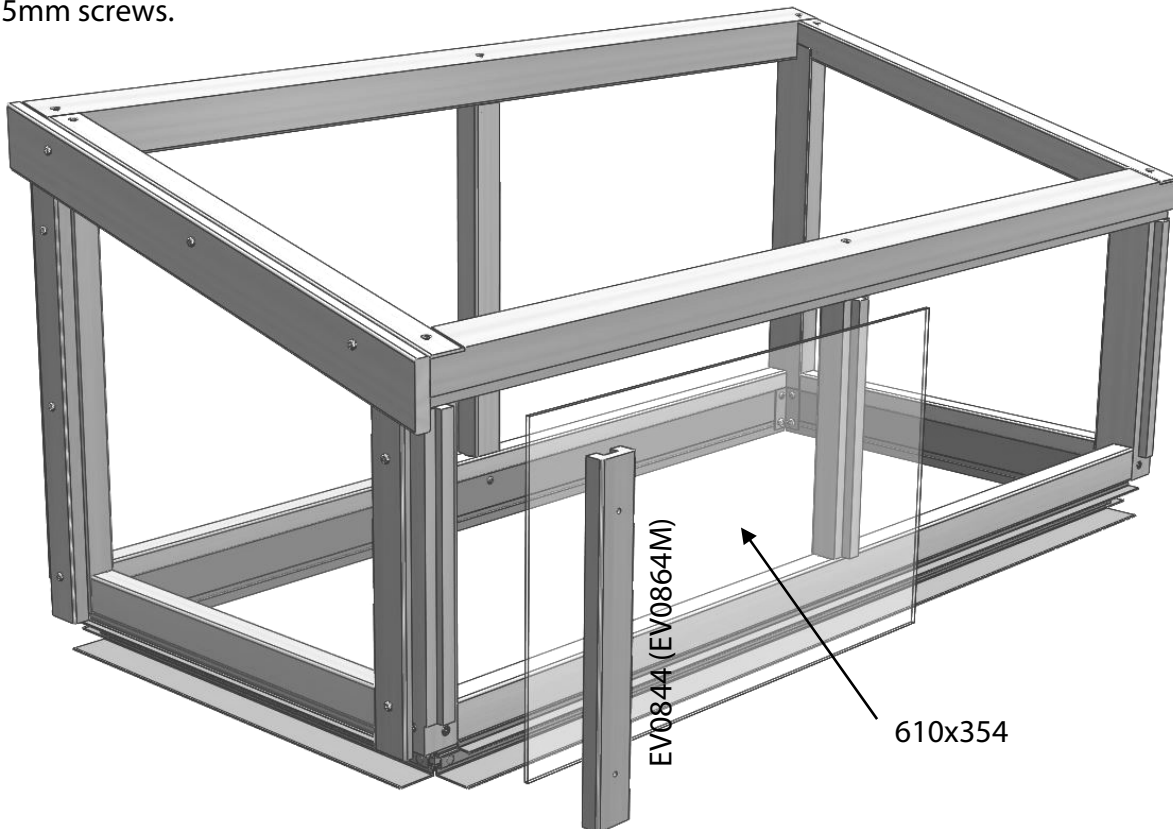

Glazing

Insert the next pane and fix with the remaining 2 front capping pieces. The middle capping will need a 40mm screw in the bottom hole.

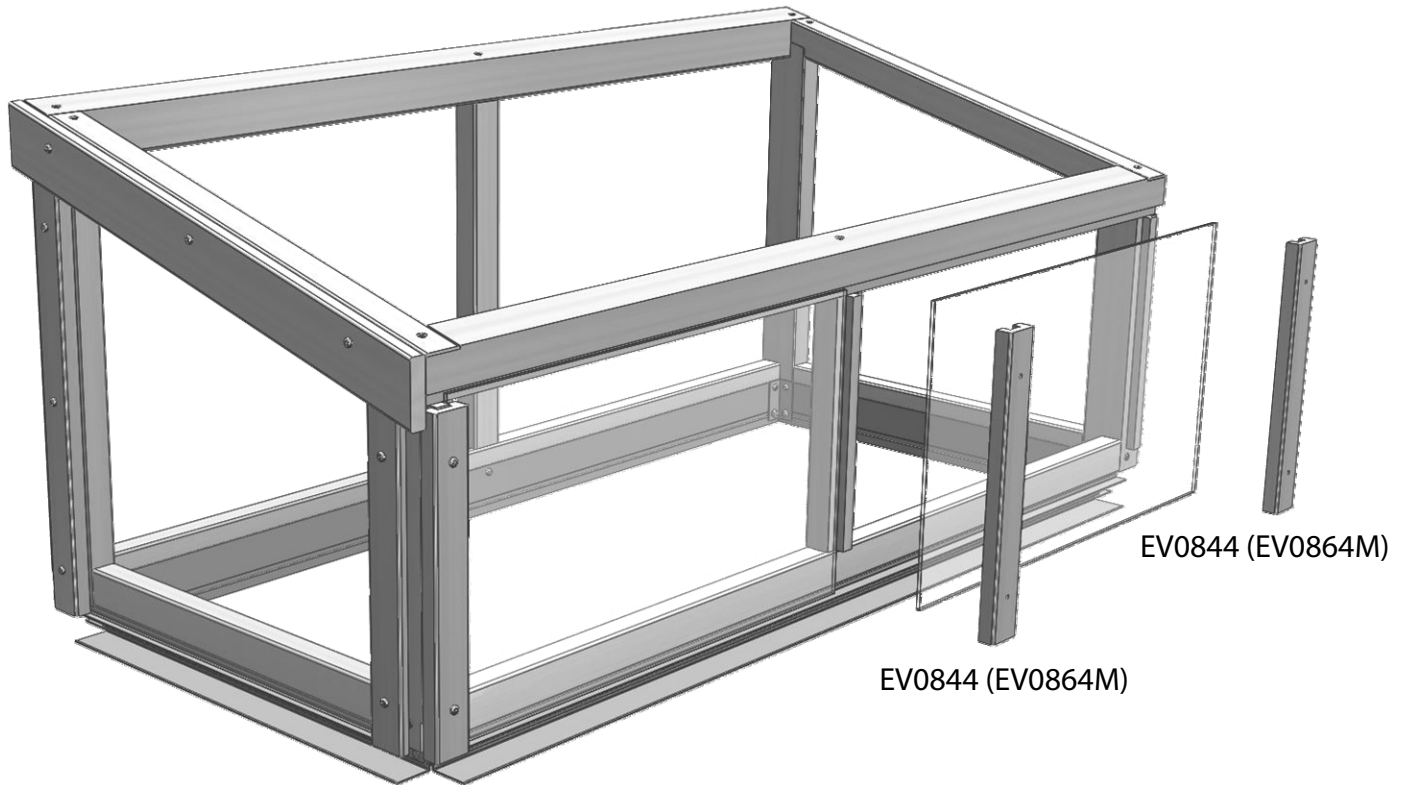

Next attach the horizontal capping with 25mm screws. This should sit flush on top of the capping and glazing bars.

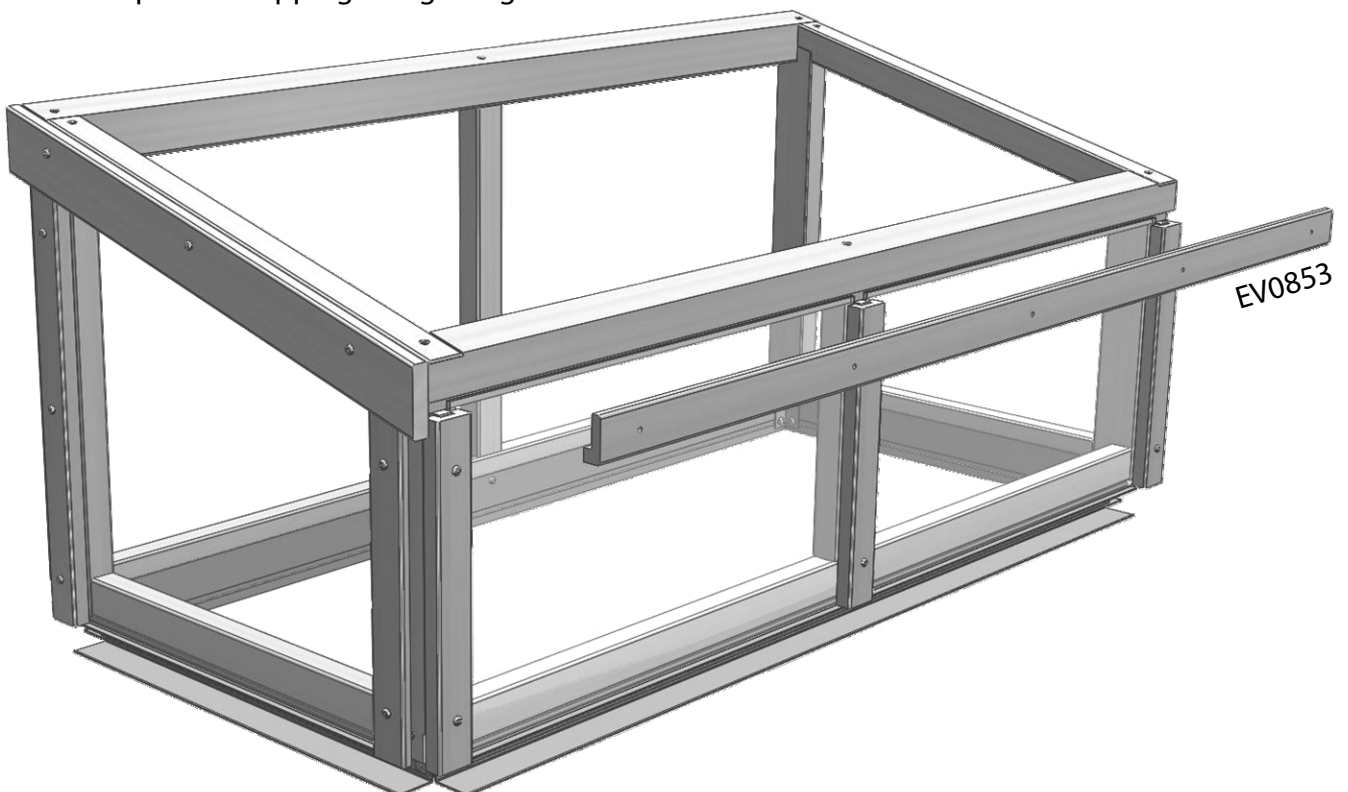

Glazing

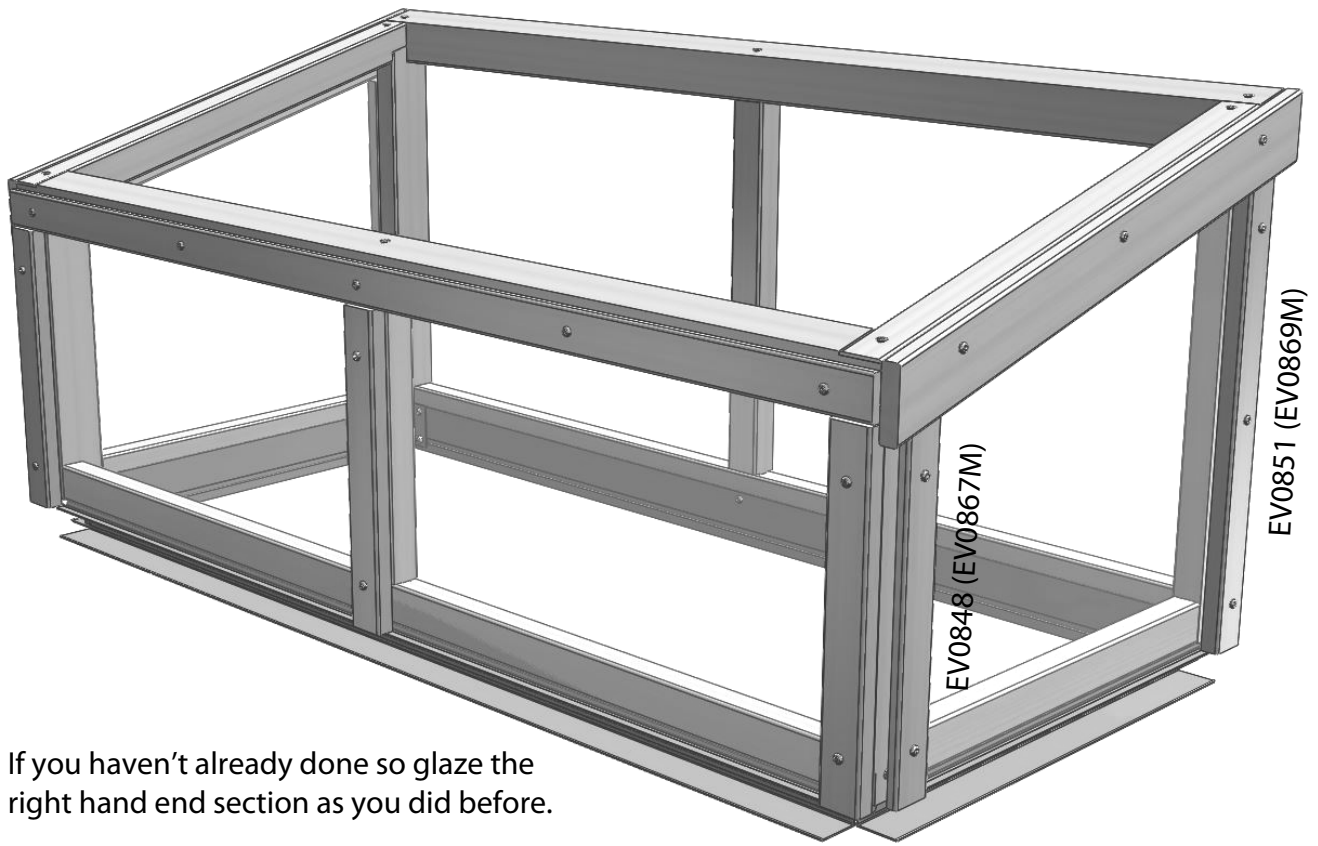

If you haven't already done so glaze the right hand end section as you did before.

Glaze the rear of the cold frame with the same method as you did with the front. Remember the bottom hole on the middle capping will need a 40mm screw. Once the vertical capping is fitted you can then install the horizontal capping as shown below.

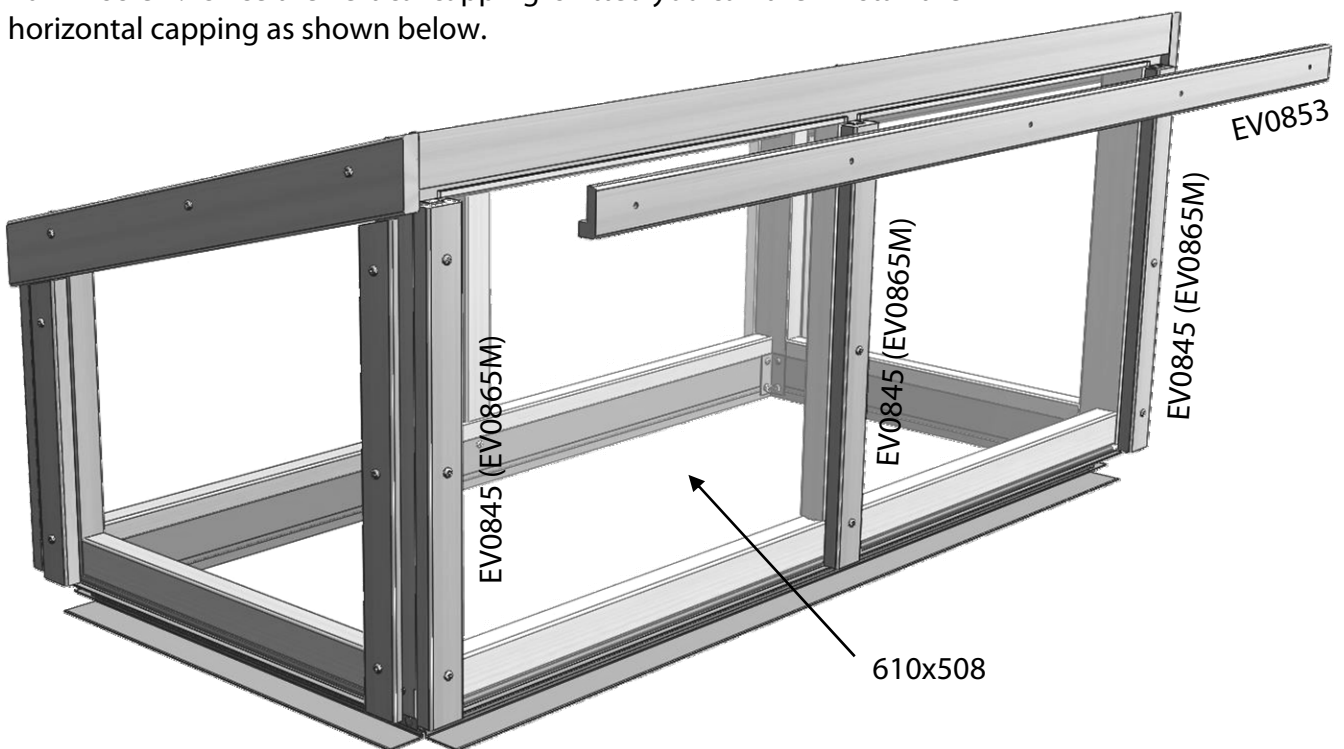

Lid Assembly

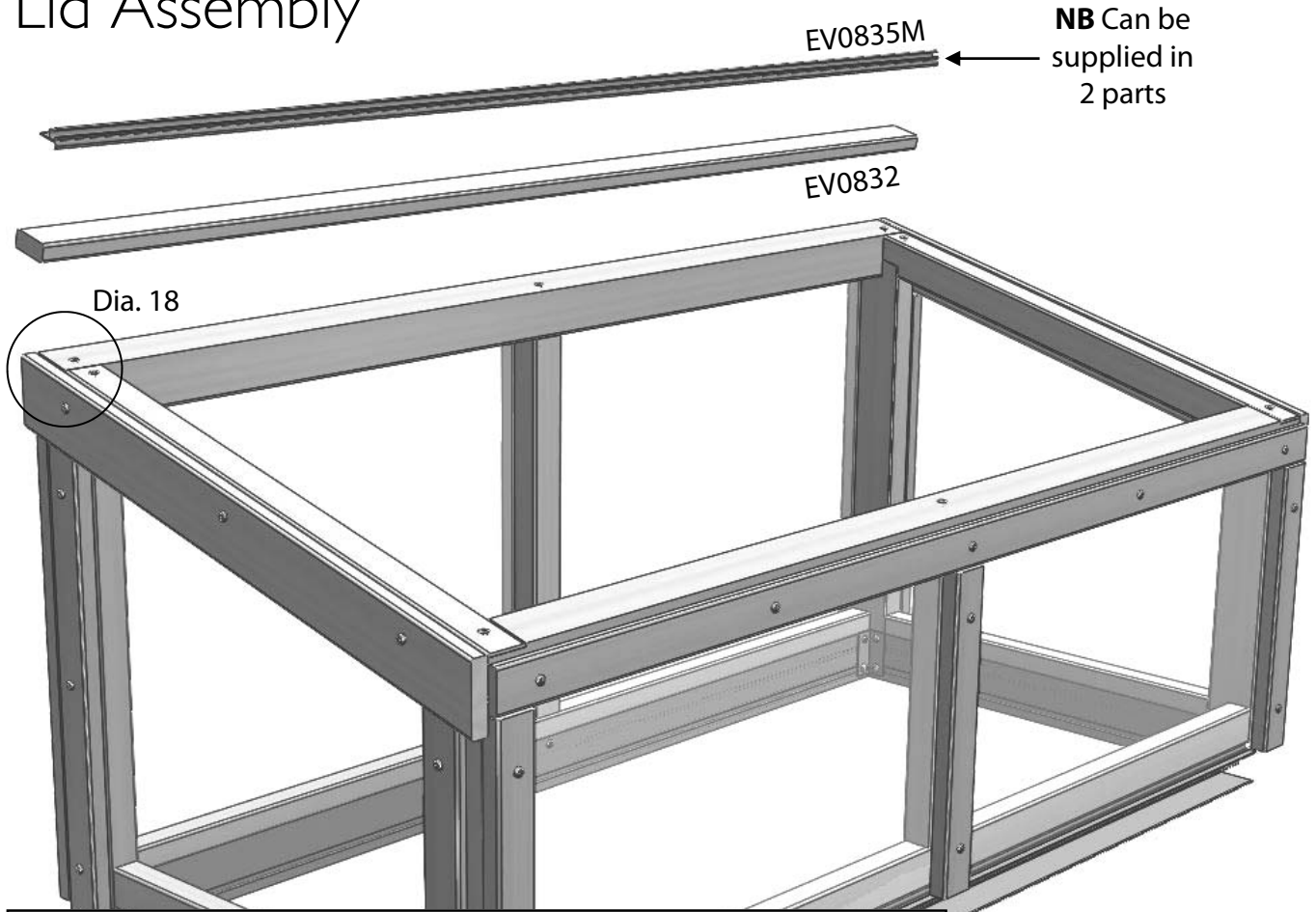
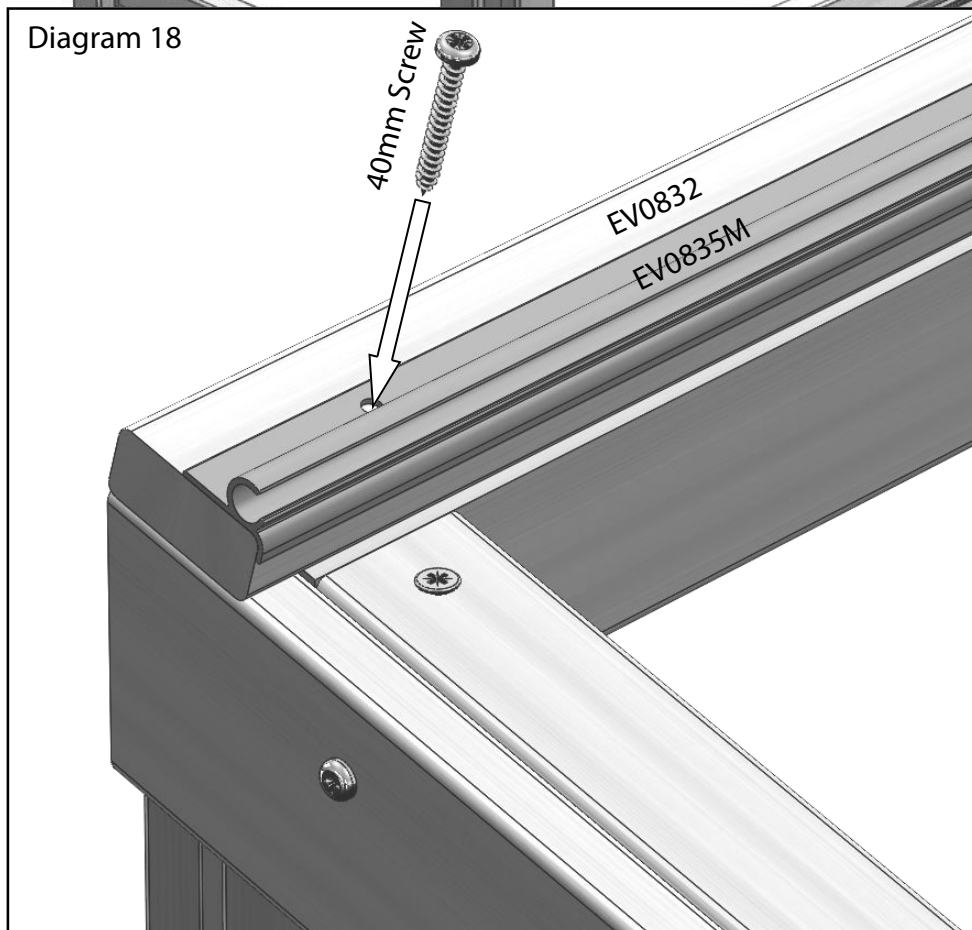

Diagram 18



You can now start fitting the lid to the cold frame. Take the top hinge board (EV0832) and the top hinge (EV0835M), position these along the top edge of the cold frame and fix with 40mm screws.

(N.B. the top hinge can sometimes be supplied in 2 sections, simply butt these together)

Lid Assembly

You can now fit the lid supports to the frame. Use a 50mm screw and 2 x M6 washers. Screw through the pre-drilled hole in the support into to the inside face of the front top rail. Refer to diagram 19 below for the position.

 External

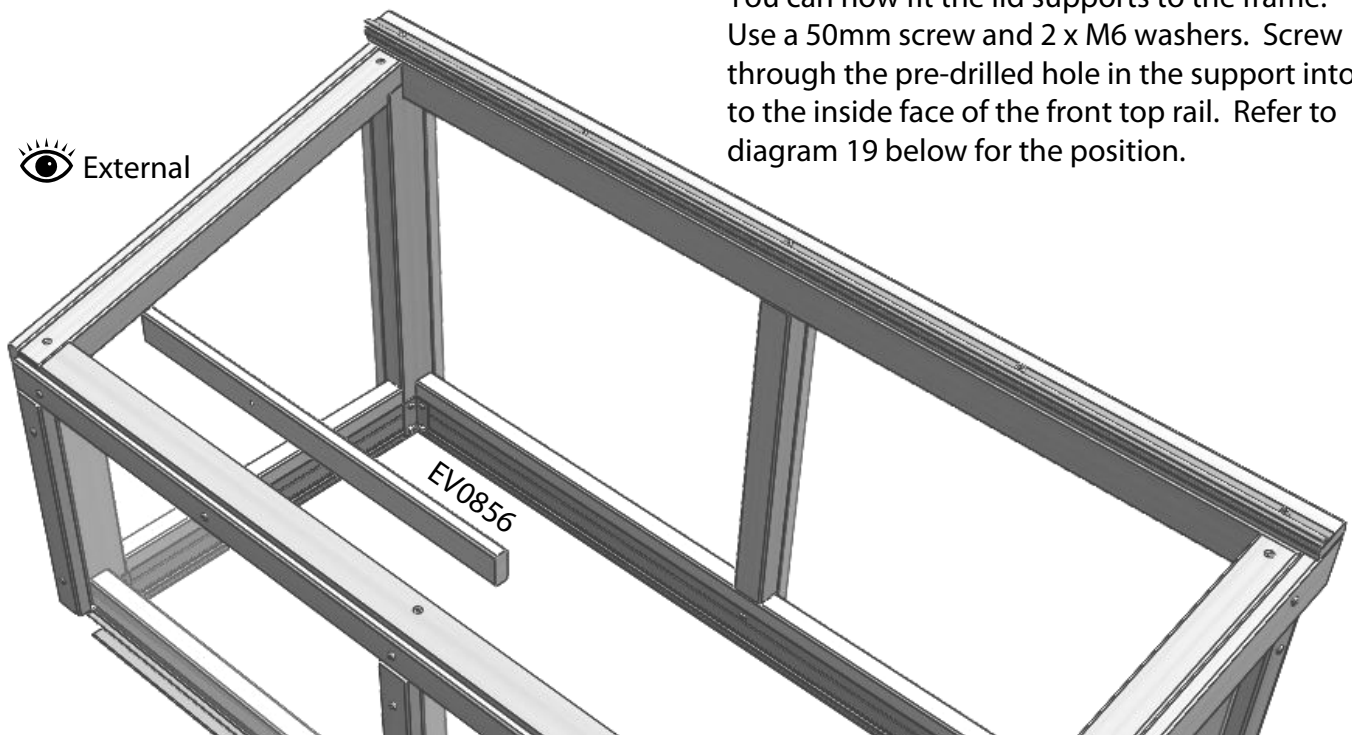

 Internal **Diagram 19**

Be careful not to over tighten the screw, it should be tight enough so the support does not move by itself but not so tight its hard to move.

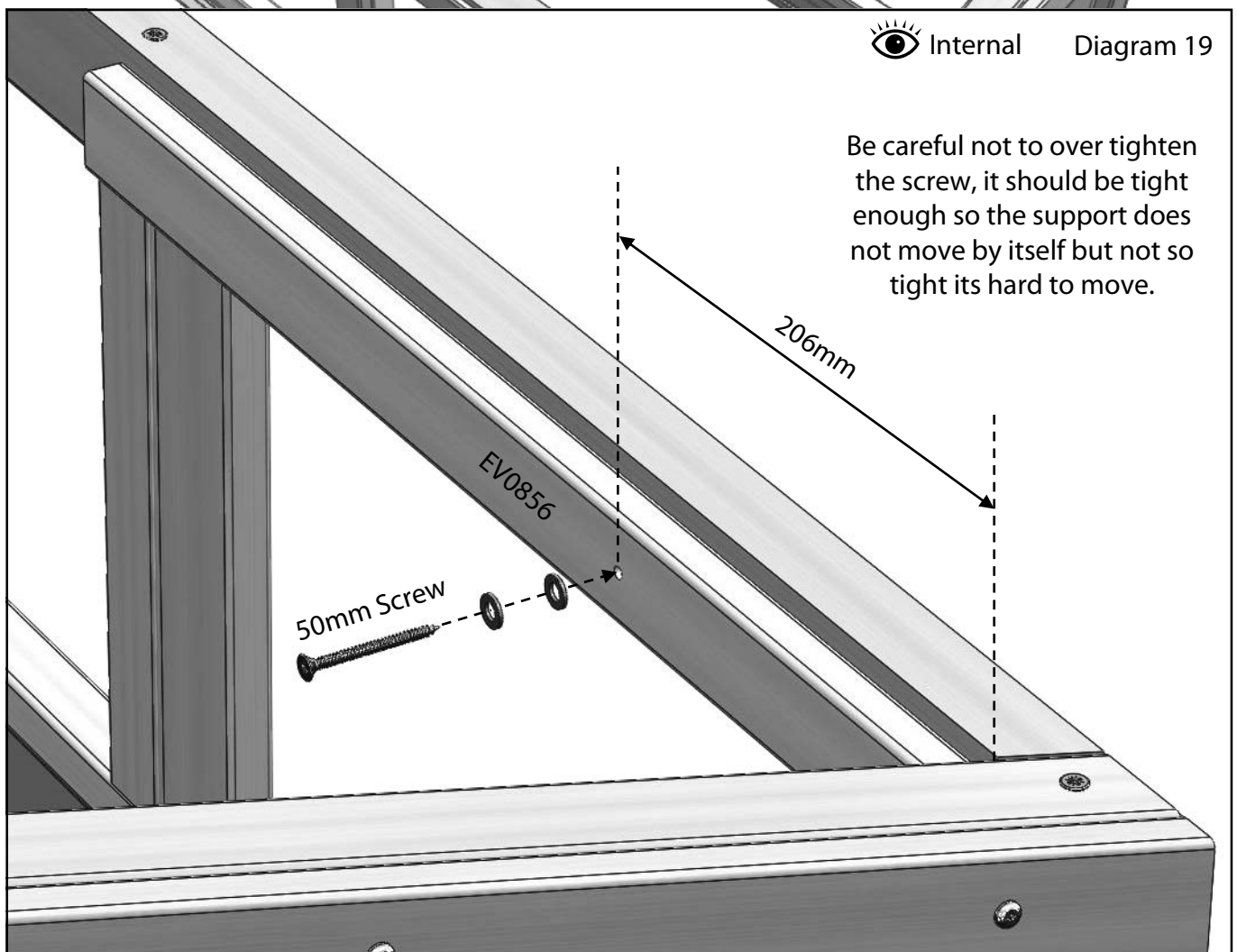

Lid Assembly

Repeat this for the second support, again checking the tightness of the screw allows the prop to move without too much effort.

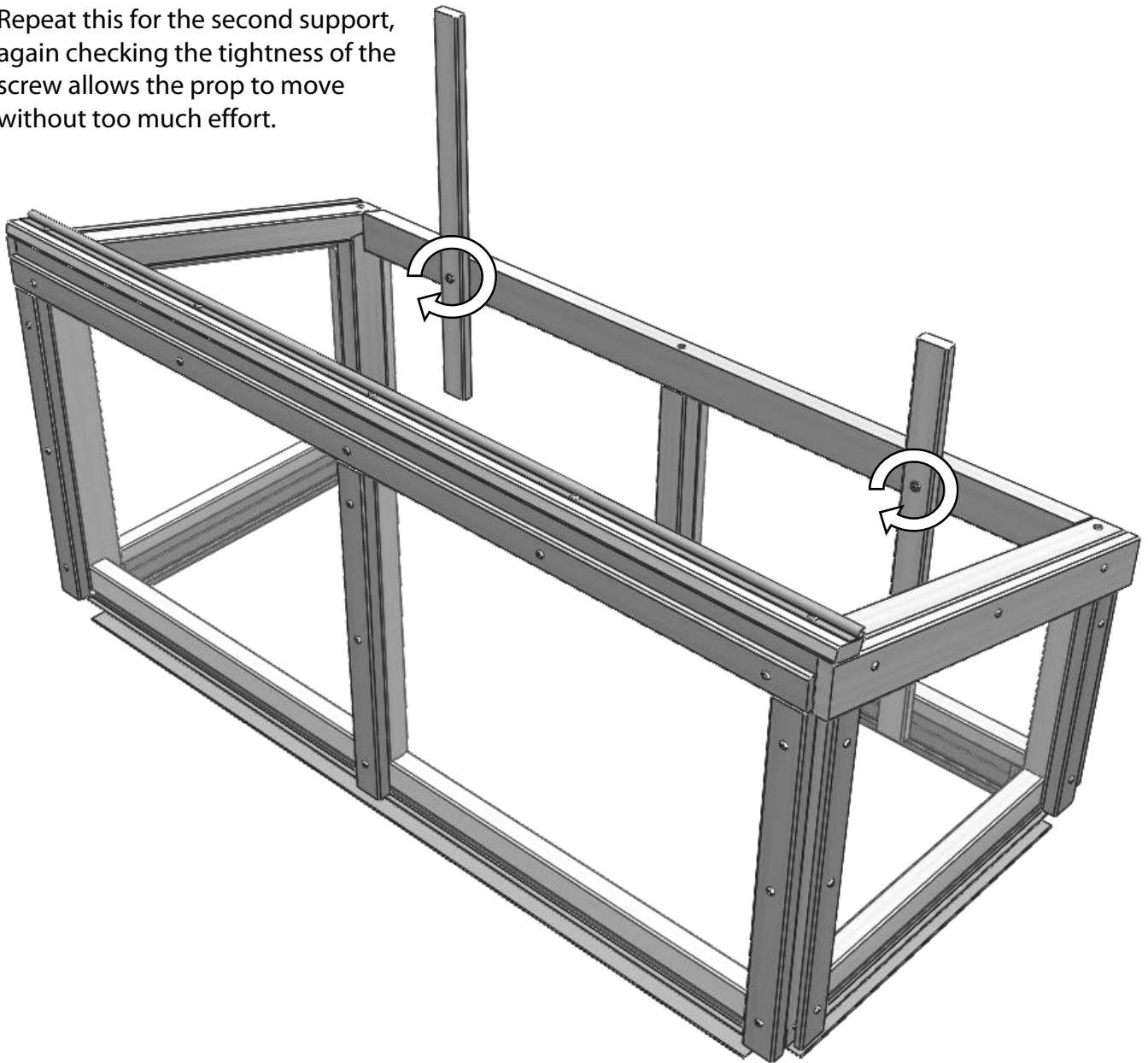

Lid Assembly

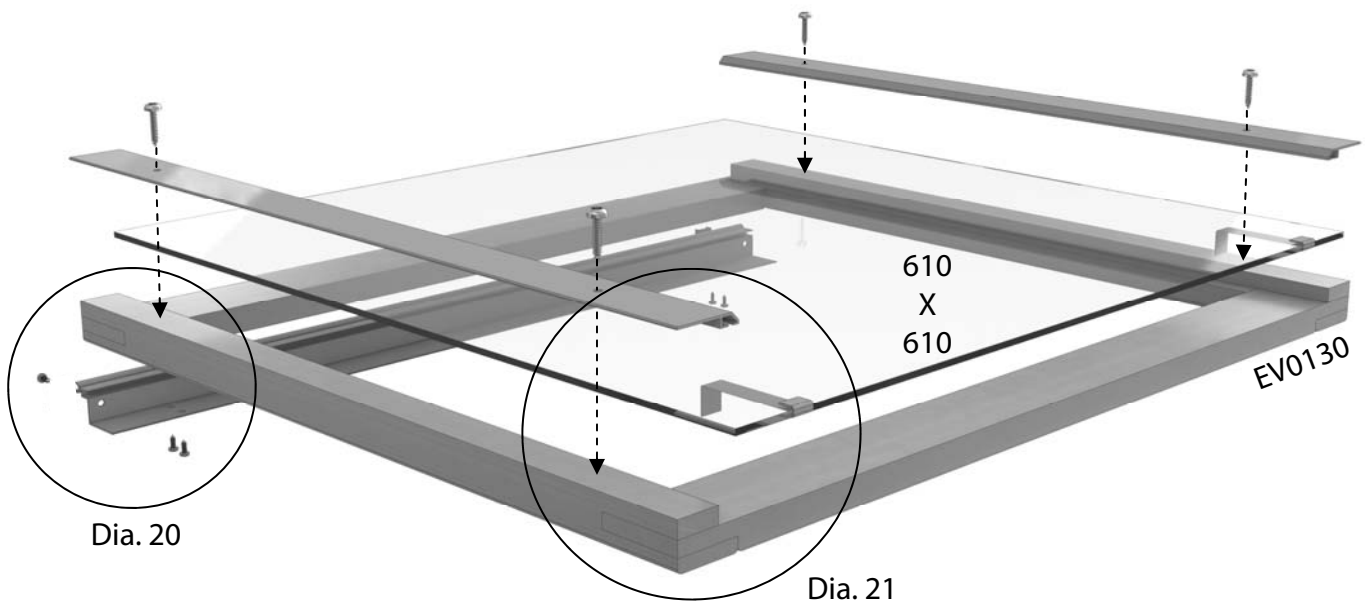

Take the vent frame that is ready assembled and fix the vent hinge to one end through the 4 pre drilled holes using the 19mm screws, diagram 20. Make a pilot hole before fixing the 19mm screw in the back of the vent to prevent it splitting.

Now take a 610mm x 610mm pane of glass and locate this in the vent hinge. Before lowering this down completely slot the glass stops onto the open edge.

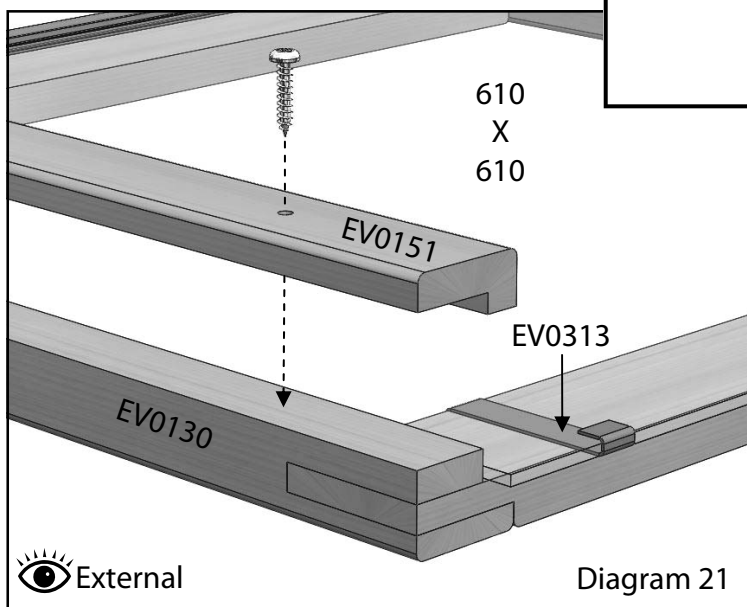
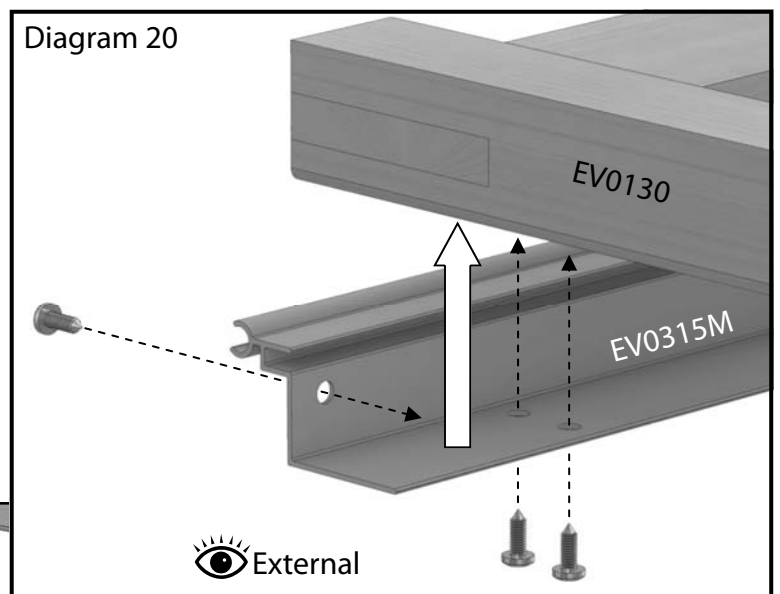

When in position you can fix the glass in place with the vent capping (either cedar or aluminium) using the 25mm screws, diagram 21. Remember if you are using the aluminium capping system you will need to insert the rubber seal before fixing it in place.

(Aluminium capping part number: EV0251M)

Lid Assembly

Next fit the handle to the lid, use 25mm screws to attach this tight under the lip of glass at the bottom of the vent. (This acts as a handle but will also protect the front edge of the glass).

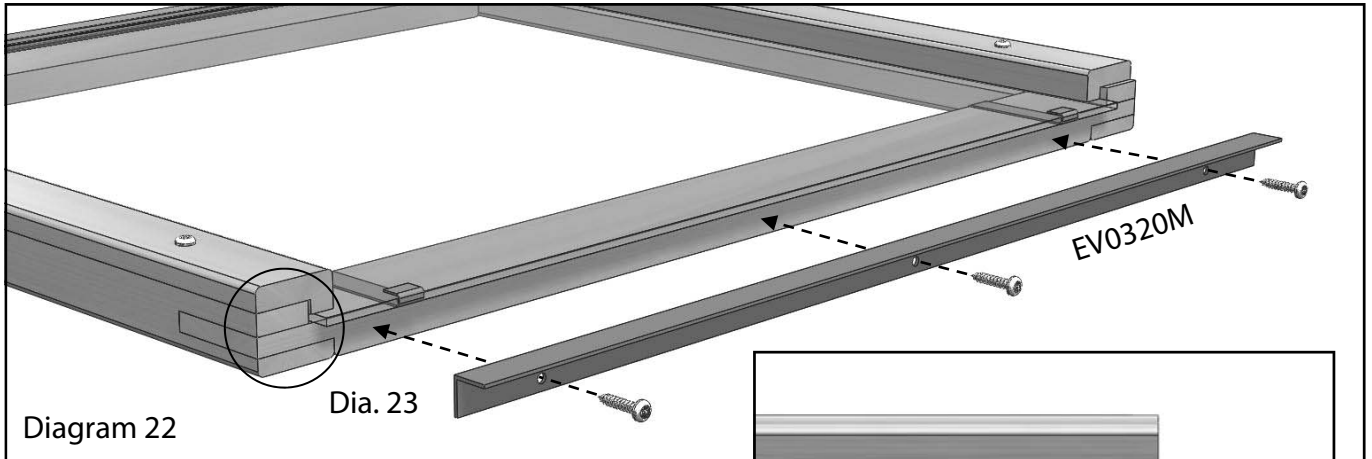

Now the lids are complete you can install them on the cold frame. Slide them along the top hinge from one end and lower into position (diagram 24). The flexible lid system gives you many different ventilation options (hinged, sliding and removable).

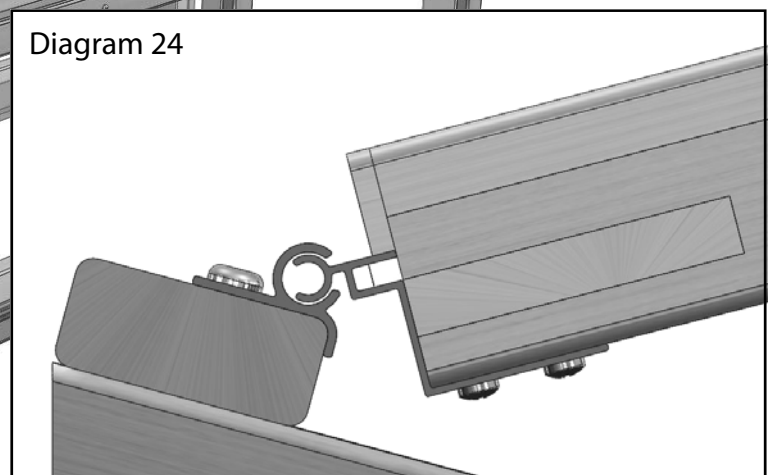
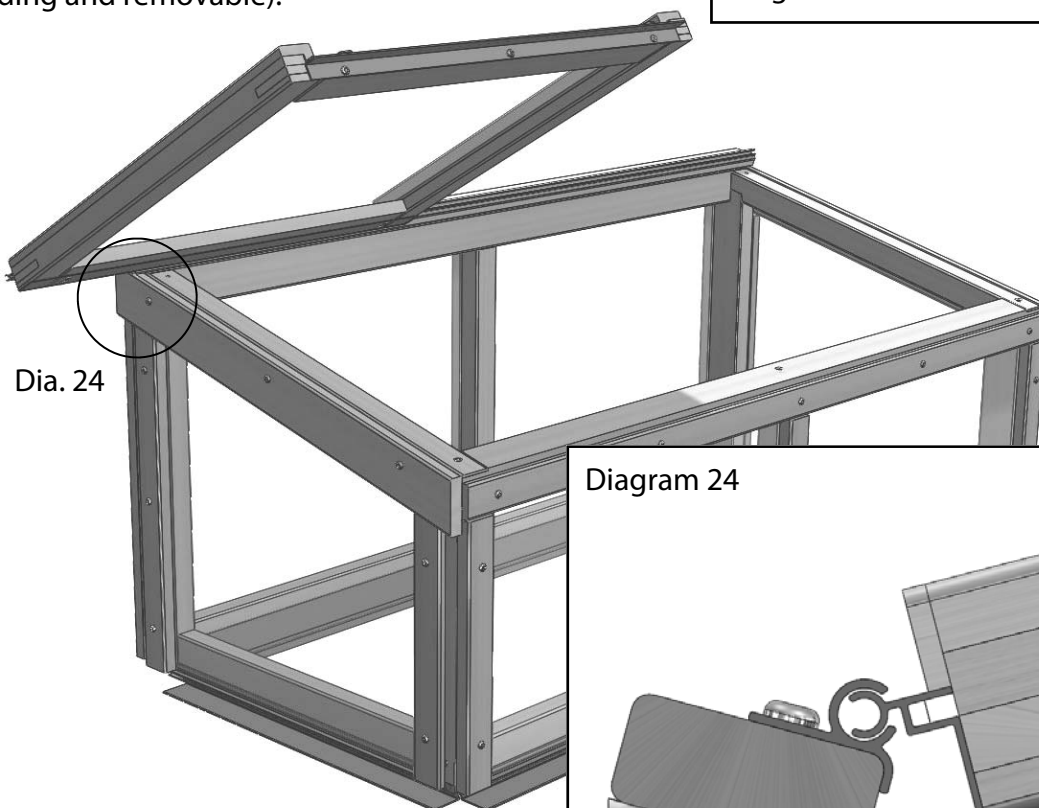
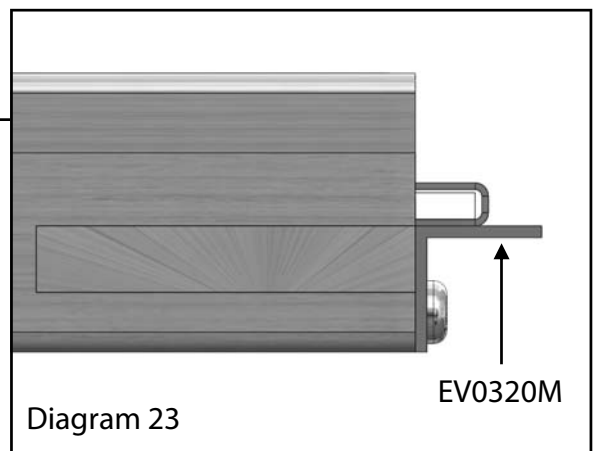

Lid Assembly

Your glazed cold frame is now complete!

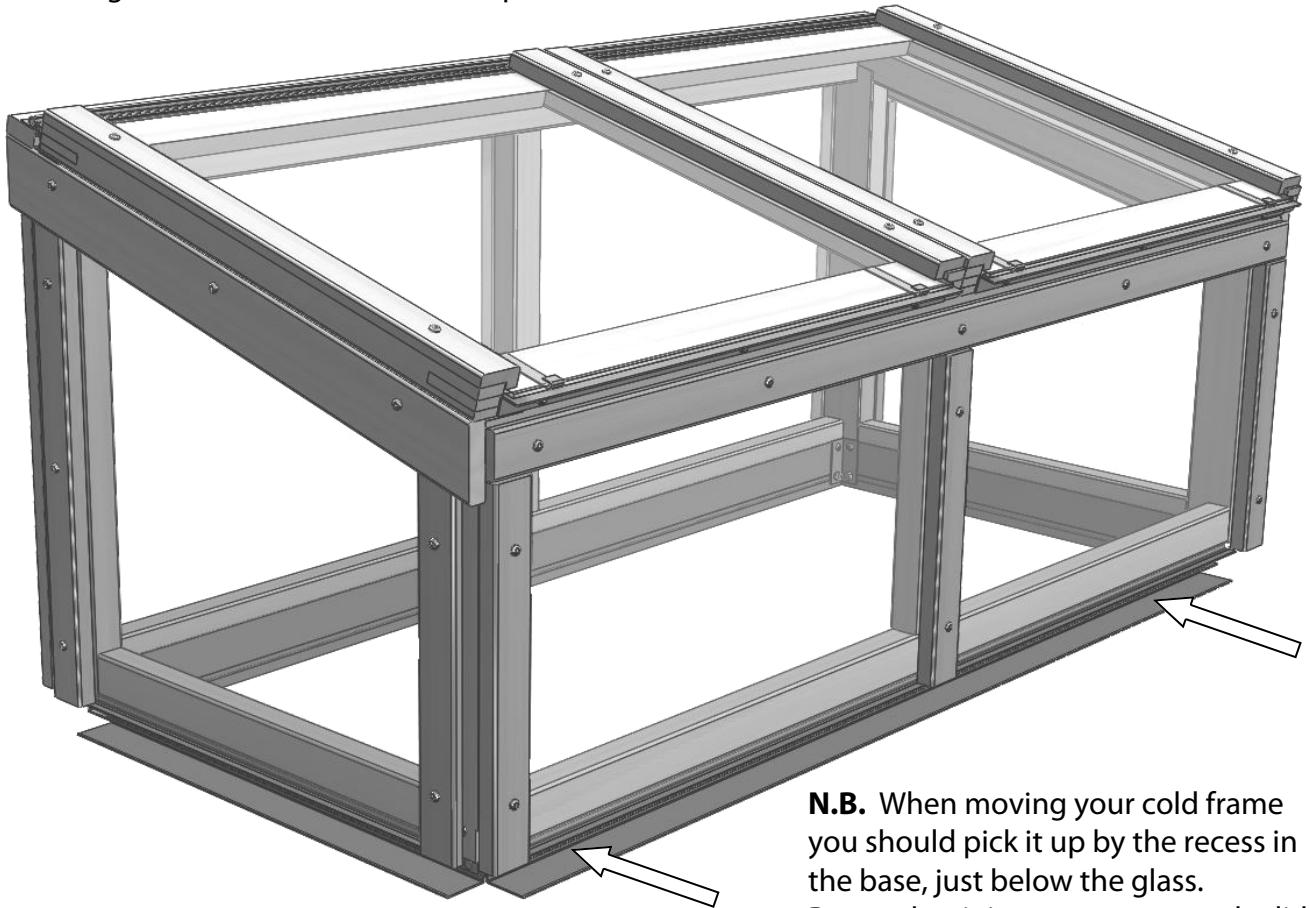

N.B. When moving your cold frame you should pick it up by the recess in the base, just below the glass. Remember it is easy to remove the lid so this is also a good idea when lifting the cold frame.

Cedar Panel Installation (Optional)

This is a fully flexible panel kit, if you want to part glaze the cold frame and only use some of the boards this is entirely possible. So it is worth considering this before you start.

All panel capping is fitted using 40mm screws

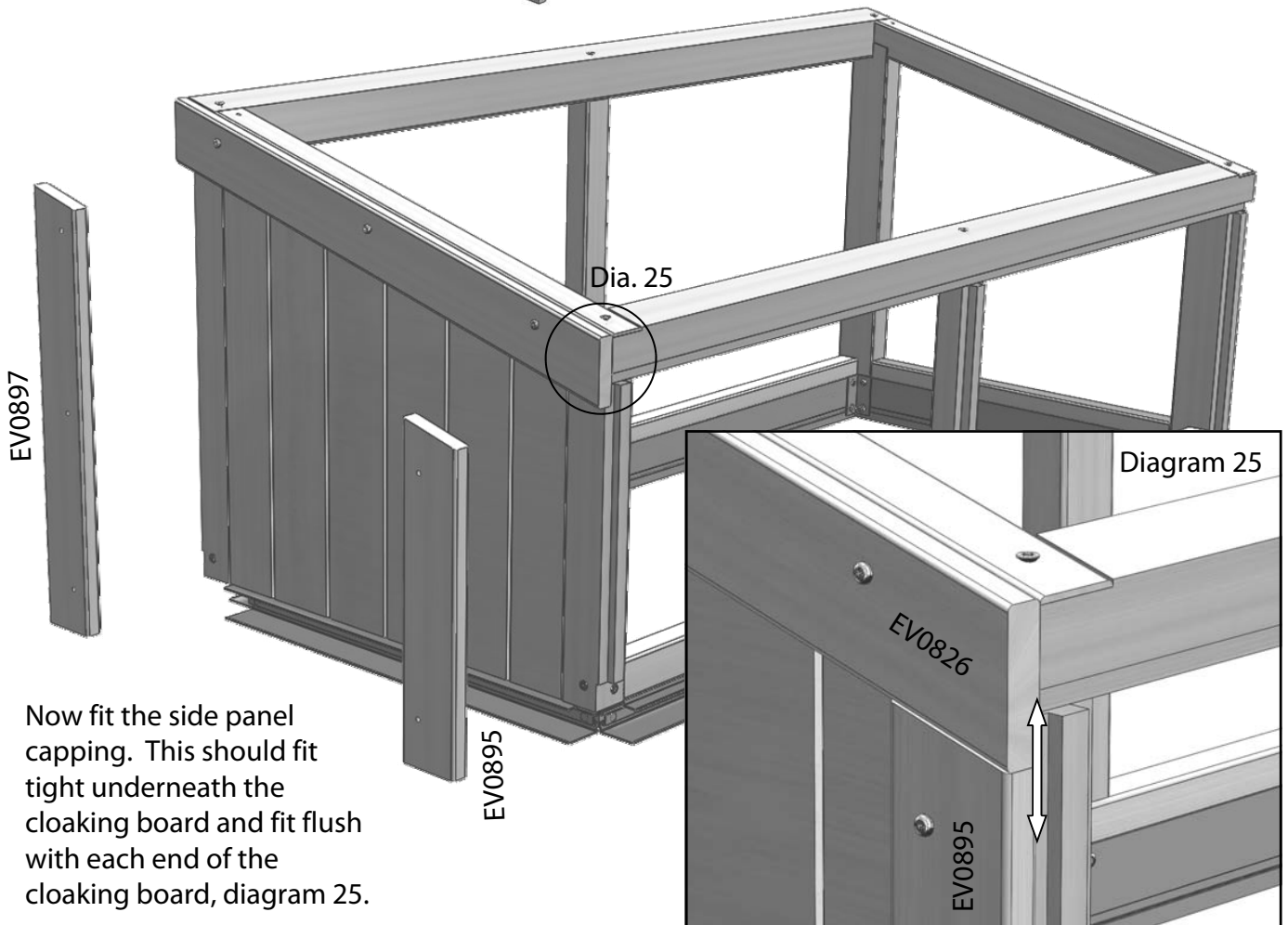
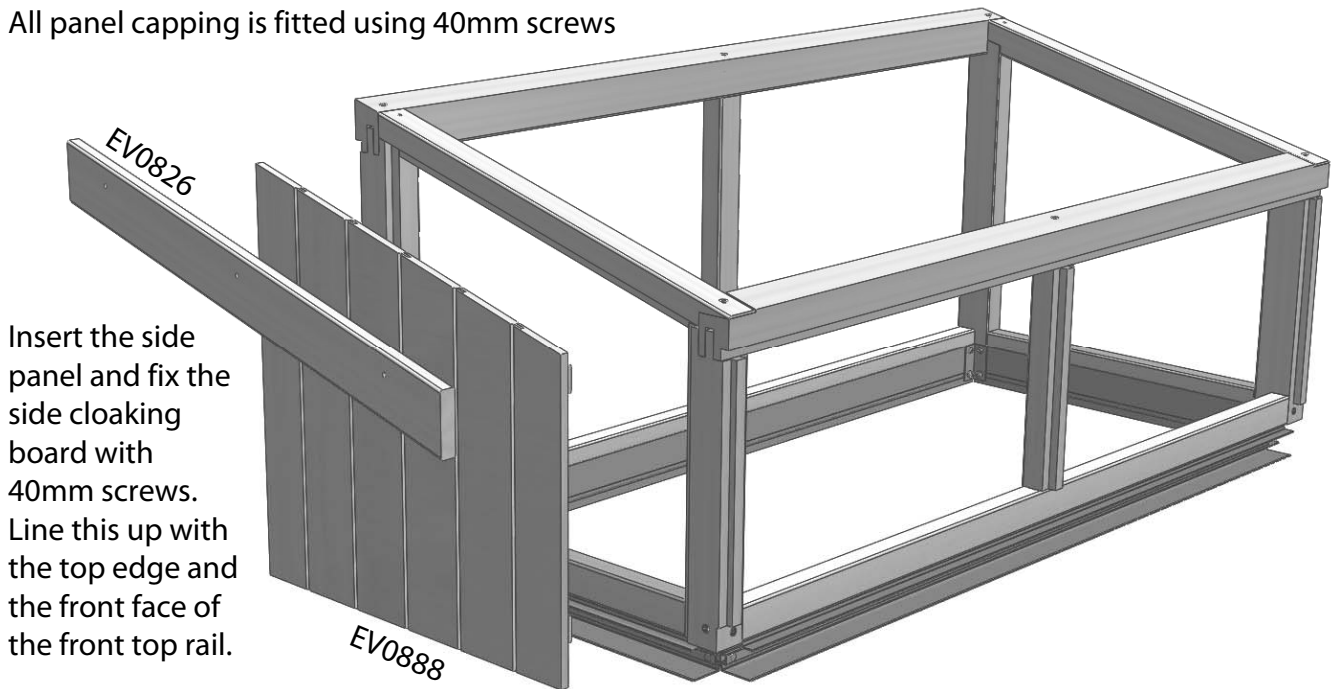

Cedar Panel Installation (Optional)

Insert the front panel and fix with the first piece of front panel capping, the capping should be flush with the top of the glazing bar it is being fixed to. You should keep the gap between the front capping and the side capping as small as possible.

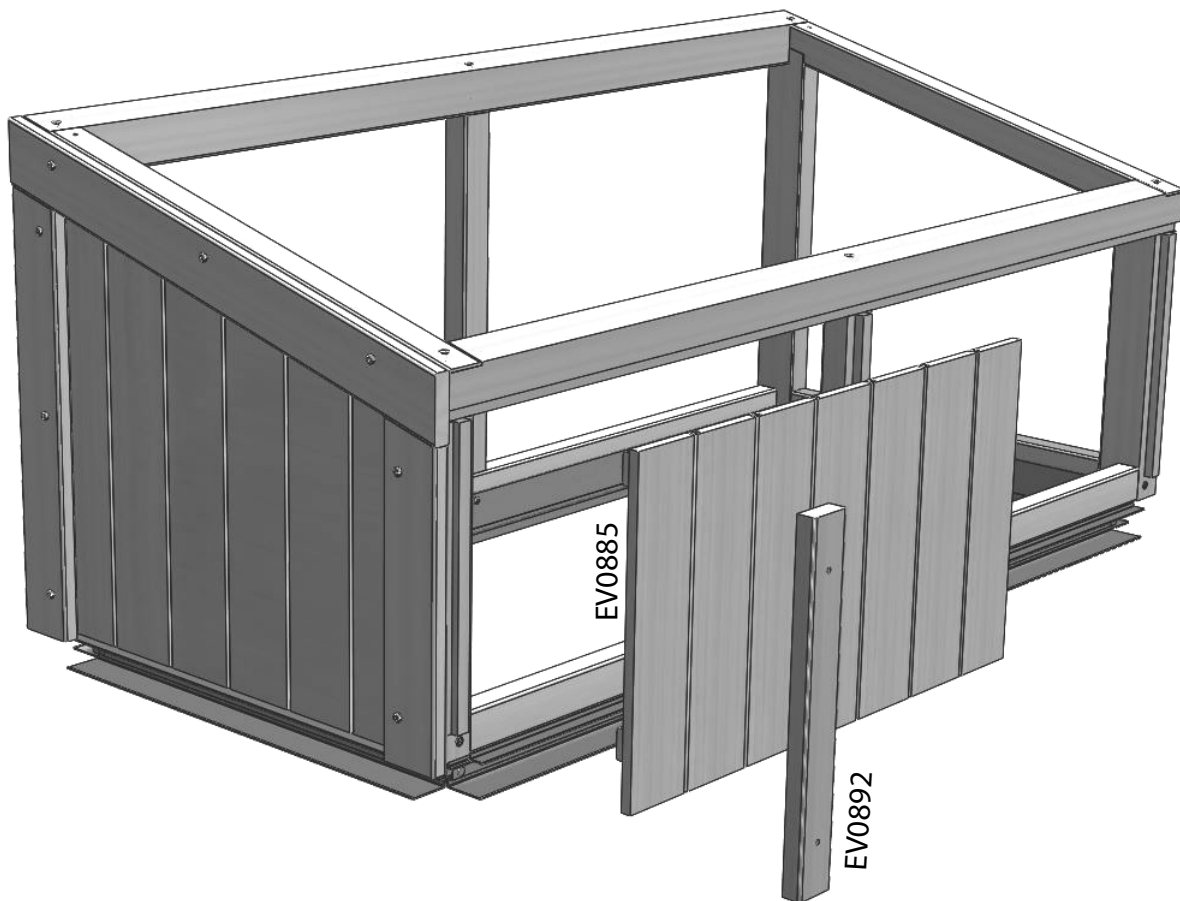

Insert the next panel and fix with the remaining 2 front capping pieces.

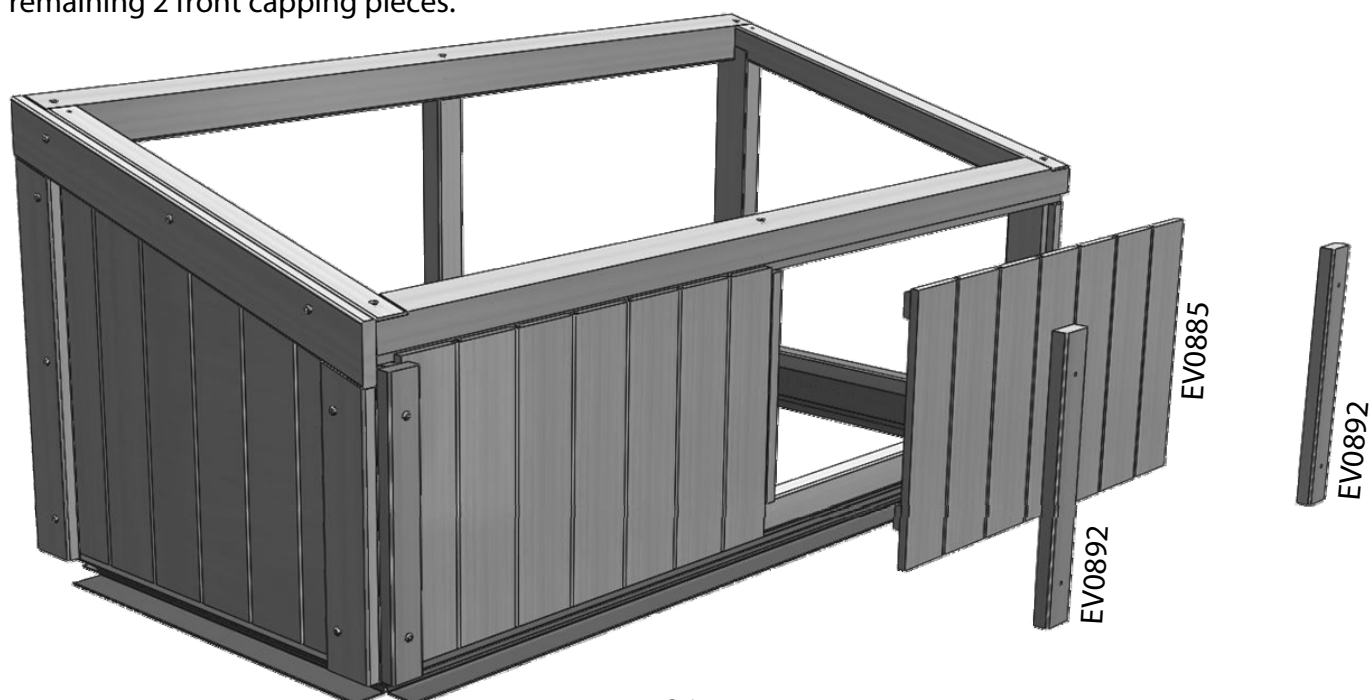

Cedar Panel Installation (Optional)

Next attach the horizontal capping, this should sit flush on top of the front panel capping.

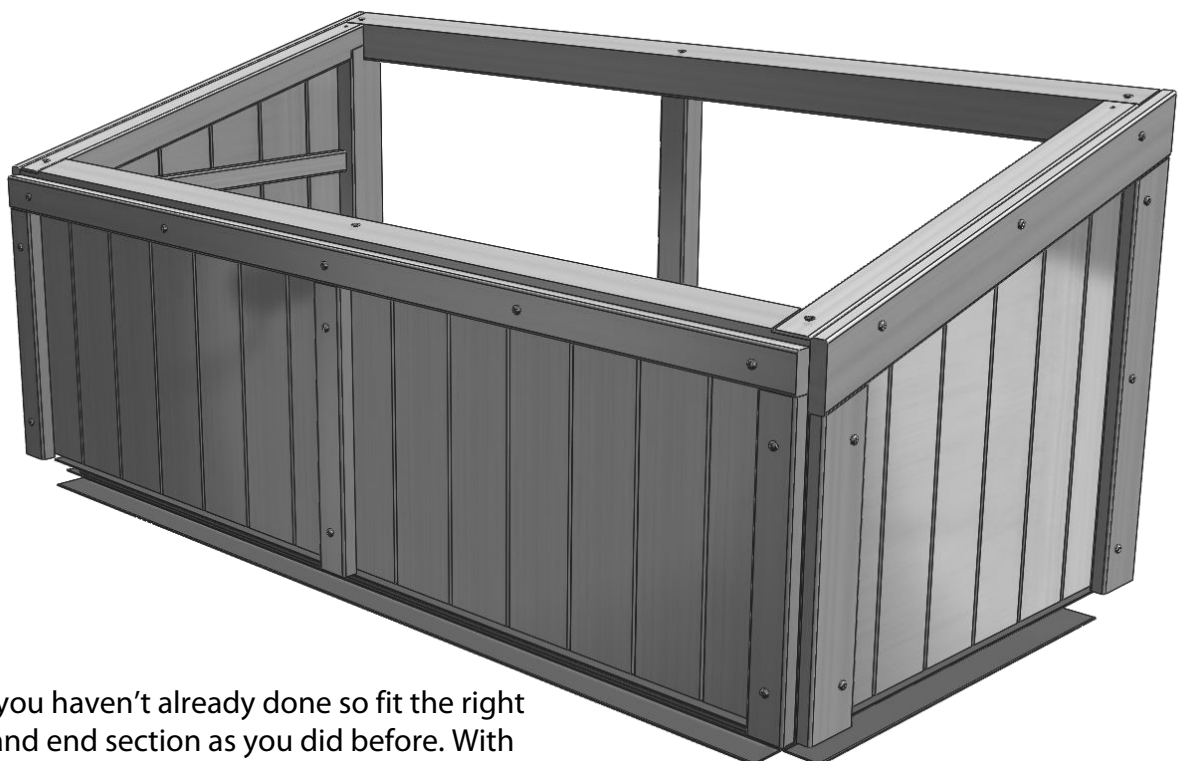
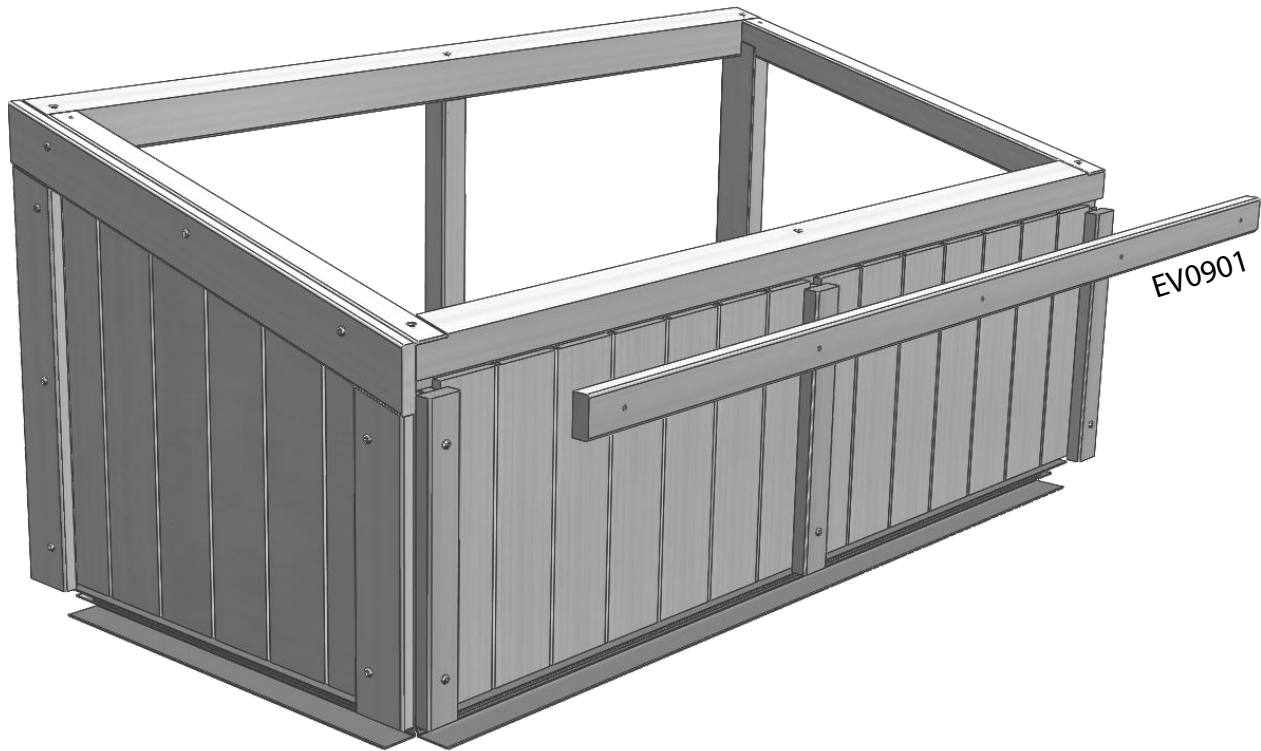

If you haven't already done so fit the right hand end section as you did before. With the left

Cedar Panel Installation (Optional)

Install the rear panels with the same method as you did with the front. Once the vertical capping is fitted you can then install the horizontal capping as shown opposite.

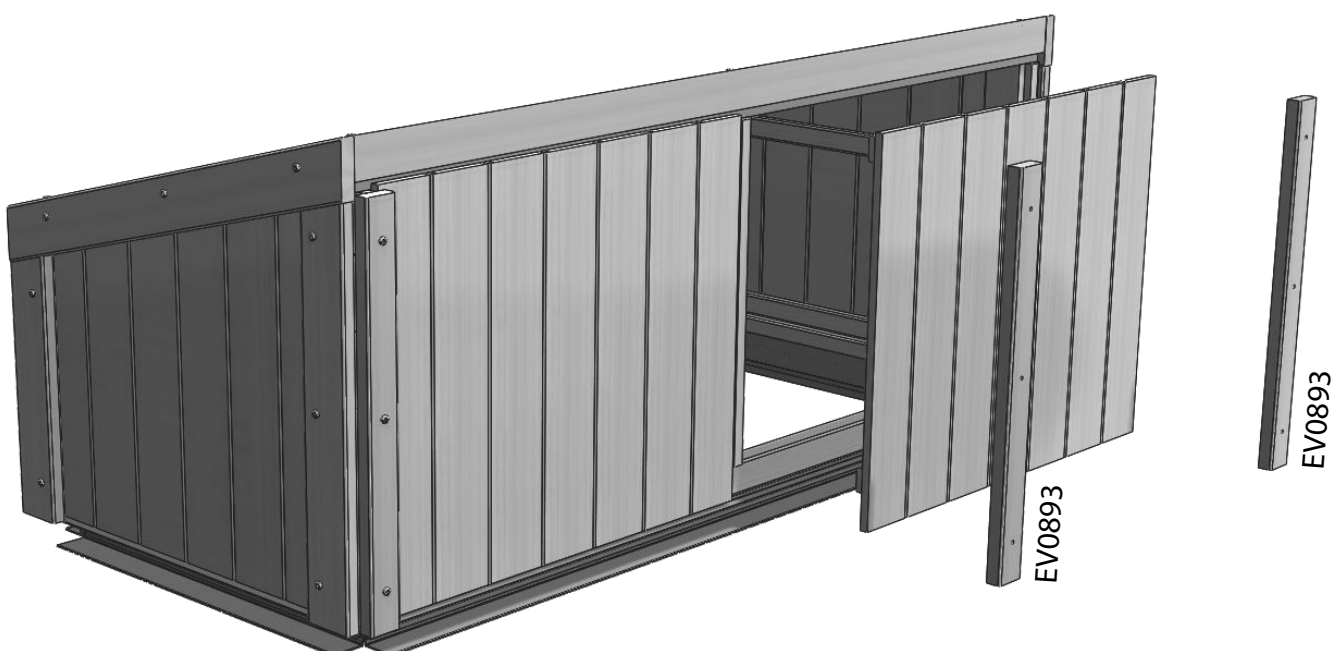
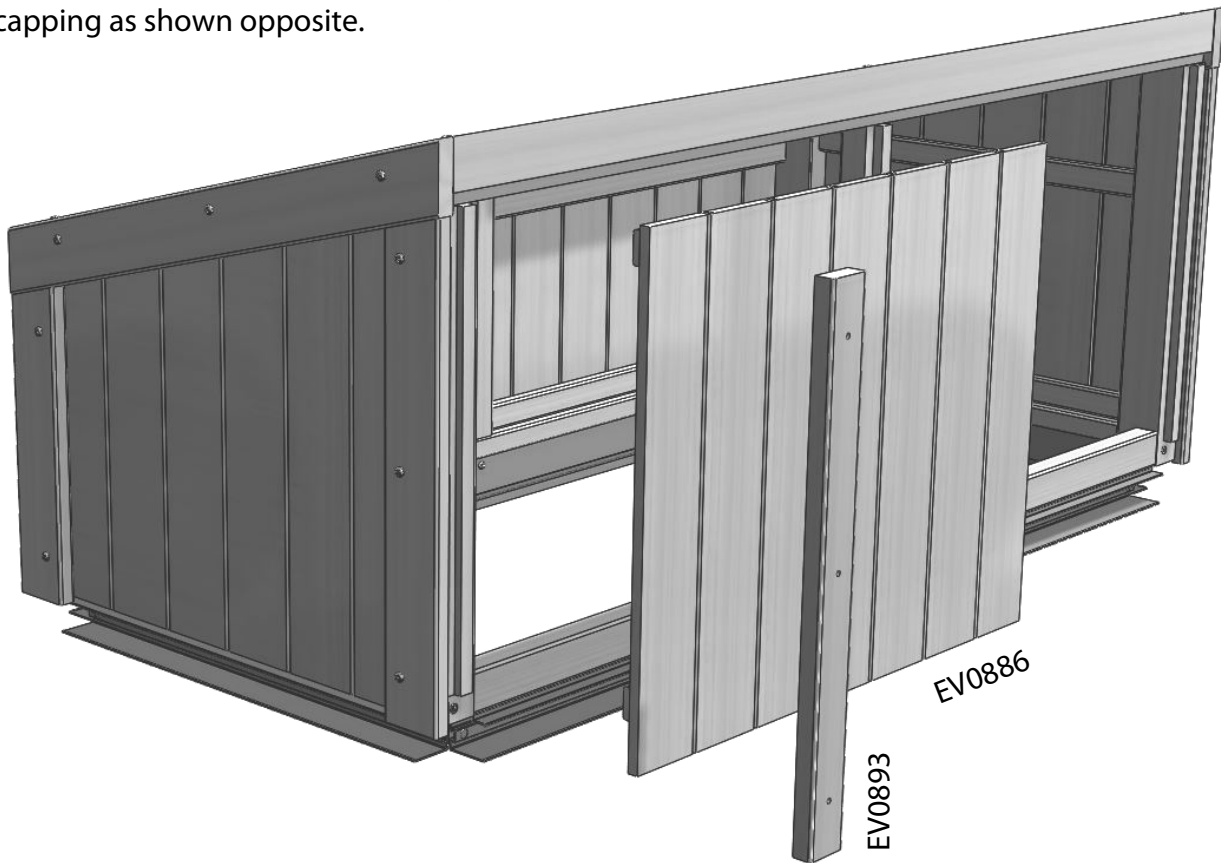

Cedar Panel Installation (Optional)

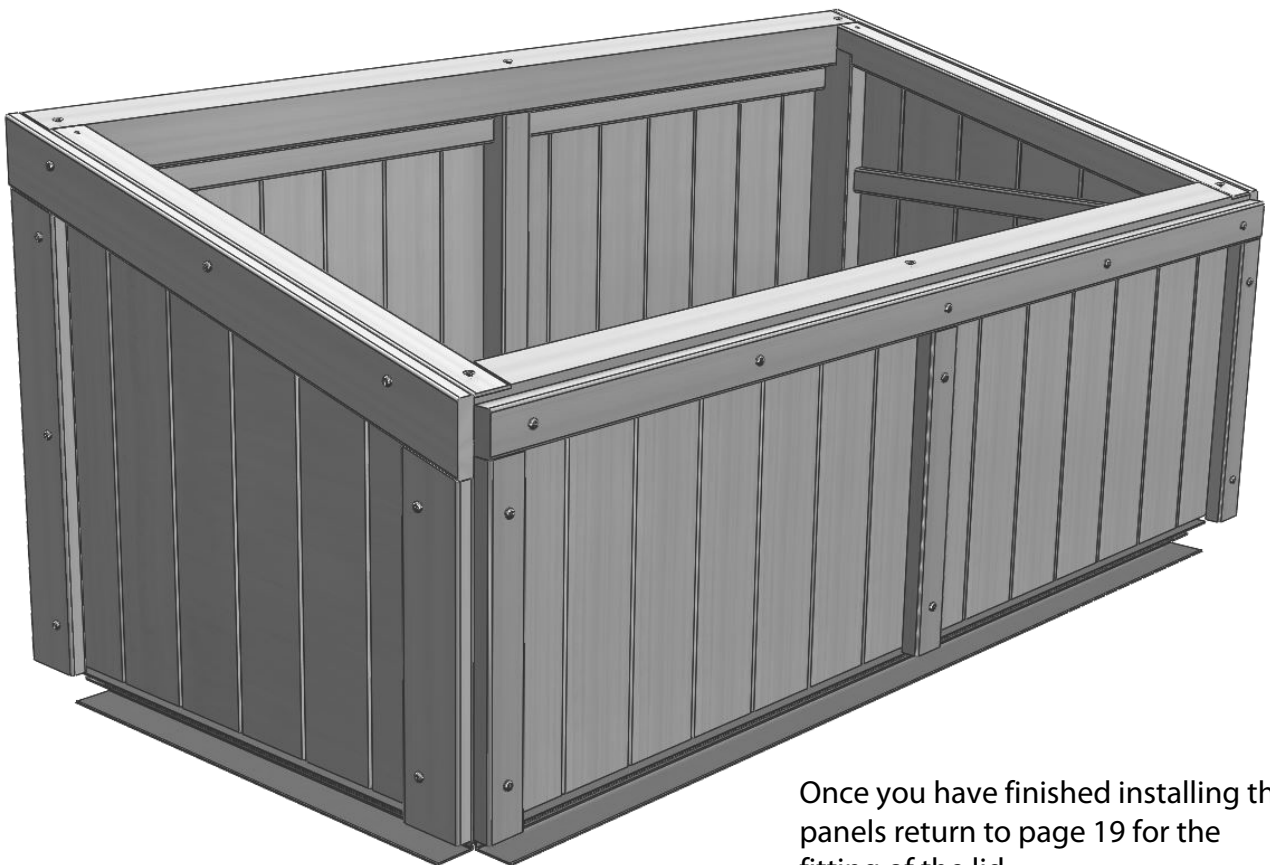

Once you have finished installing the panels return to page 19 for the fitting of the lid.

Packing List

Description:	Alton Evolution Cold Frame 2ft x 4ft	
Product Code	Description	Quantity
EVSMACOL24	Smalls Pack for Evolution Cold Frame 2x4	1
EV0130	Vent Assembled EV0130	2
EV0800	Cold Frame Front and Rear Cill 4ft EV0800 1222mm	2
EV0803	Cold Frame Side Cill 2ft EV0803 545mm	2
EV0805	Cold Frame Front Top Rail 4ft EV0805 1310mm	1
EV0808	Cold Frame Rear Top Rail 4ft EV0808 1310mm	1
EV0811	Cold Frame Side Top Rail Left 2ft EV0811 600mm	1
EV0813	Cold Frame Side Top Rail Right 2ft EV0813 600mm	1
EV0815	Cold Frame Front Corner Post Left EV0815 372mm	1
EV0816	Cold Frame Front Corner Post Right EV0816 372mm	1
EV0817	Cold Frame Rear Corner Post Left 2ft EV0817 527mm	1
EV0819	Cold Frame Rear Corner Post Right 2ft EV0819 527mm	1
EV0821	Cold Frame Front Centre Post EV0821 346mm	1
EV0822	Cold Frame Rear Centre Post 2ft EV0822 500mm	1
EV0826	Cold Frame Side Cloaking Board 2ft EV0826 664mm	2
EV0832	Cold Frame Top Hinge Board 4ft EV0832 1348mm	1
EV0856	Cold Frame Lid Support EV0856 600mm	2
EV0315M	Alu Vent Hinge EV0315M 674mm **MOSS**	2
EV0320M	ALU Door Guide Bracket 630 EV0320 630mm **MOSS**	2
EV0835M	Cold Frame Top Hinge 4ft EV0835M 1348mm **MOSS**	1
EV0838M	Cold Frame Front and Rear Base 4ft EV0838M 1216mm **MOSS**	2
EV0841M	Cold Frame Side Base 2ft EV0841M 513mm **MOSS**	2
D119	Silicone Clear 80ml	1
INS	Alton Evolution Cold Frame Instruction Manual	1

Description:	Alton Evolution Cold Frame 2ft x 4ft Cedar Panels	
Product Code	Description	Quantity
EV0885	Cold Frame Front Panel EV0885 610x347mm	2
EV0886	Cold Frame Rear Panel EV0886 610x501mm	2
EV0888	Cold Frame Side Panel Left EV0888 509x512x376	1
EV0890	Cold Frame Side Panel Right EV0890 509x512x376	1
EV0892	Cold Frame Front Panel Capping EV0892 345mm	3
EV0893	Cold Frame Rear Panel Capping EV0893 500mm	3
EV0895	Cold Frame Side Panel Capping Front EV0895 345mm	2
EV0897	Cold Frame Side Panel Capping Rear EV0897 493mm	2
EV0901	Cold Frame Horizontal Panel Capping 4ft EV0901 1310mm	2
EV0332	40mm x 4 Pan Poz A2 SS woodscrew EV0332	35

Packing List

Description: Smalls Pack for Alton Evolution Cold Frame 2ft x 4ft		
Product Code	Description	Quantity
D174M	Base bracket D174 ***MOSS***	4
EV0311M	ALU Base Joining Bracket EV0311 60mm **MOSS**	4
EV0313M	Glass Stop EV0313 **MOSS**	4
EV0328	19mm x 4 Pan Pozi A2 Stainless screw	12
EV0331	25mm x 4 Pan Pozi woodscrew A2 SS EV0331	61
EV0332	40mm x 4 Pan Poz A2 SS woodscrew EV0332	11
EV0333	50mm x 5 Csk pozi woodscrew A2 SS EV0333	6
EV0334	80mm x 5 Csk pozi woodscrew A2 SS EV0334	14
EV0337	4mm Drill Bit	1
SYBOLM6X11	Bolts 11mm M6 (simp) ABCX060011	8
SY-BOLM6X11CR OP	M6X 11mm Cropped Head Bolts	4
SYNUTM6	Nuts M6 Alu ANFM060	12
02-1898	Washer 1/4in Table 4 Light Zp	4

Description: Alton Evolution Cold Frame 2ft x 4ft Cedar Capping		
Product Code	Description	Quantity
EV0151	Roof Vent Capping EV0151 596mm	4
EV0844	Cold Frame Front Capping EV0844 345mm	3
EV0845	Cold Frame Rear Capping EV0845 500mm	3
EV0847	Cold Frame Side Capping Front Left EV0847 345mm	1
EV0848	Cold Frame Side Capping Front Right EV0848 345mm	1
EV0849	Cold Frame Side Capping Rear Left EV0849 486mm	1
EV0851	Cold Frame Side Capping Rear Right EV0851 486mm	1

Description: Alton Evolution Cold Frame 2ft x 4ft Aluminium Capping		
Product Code	Description	Quantity
EV0251M	ALU Roof Vent Capping EV0251 596mm **MOSS**	4
EV0864M	Cold Frame Front Capping EV0864M 345mm **MOSS**	3
EV0865M	Cold Frame Rear Capping EV0865M 500mm **MOSS**	3
EV0867M	Cold Frame Side Capping Front EV0867M 345mm **MOSS**	2
EV0869M	Cold Frame Side Capping Rear EV0869M 500mm **MOSS**	2



0800 085 0005